

**PLANNING COMMISSION AGENDA
CITY OF PIQUA, OHIO
6:00 P.M. - TUESDAY, MARCH 9, 2010
MUNICIPAL GOVERNMENT COMPLEX
COMMISSION CHAMBERS - 201 W. WATER STREET**

CALL TO ORDER

- | | |
|-------------------|----------------------|
| 1. Chair Comments | Opening Remarks |
| 2. Roll Call | Clerk Calls the Roll |

OLD BUSINESS

- | | |
|--------------------|--|
| 3. Meeting Minutes | Adoption of February 9, 2010 Meeting Minutes |
|--------------------|--|

NEW BUSINESS

- | | |
|------------------------|---|
| 4. Resolution PC 07-10 | A resolution requesting authorization of a cellular communication tower special use of parcel N44-100580, said parcel also known as 1703 Commerce Drive. |
| 5. Resolution PC 08-10 | A resolution requesting authorization of an automobile repair, painting and body shop special use of parcel N44-073740, said parcel also known as 8620 N CR-25A. |
| 6. Resolution PC 09-10 | A resolution requesting the zoning designation of parcel N44-004010 change from B General Business to R-2 Two-Family Residential, said parcel also known as 316 N. Downing Street. |
| 7. Resolution PC 10-10 | A resolution requesting the zoning designation of parcel N44-004000 change from B General Business to R-2 Two-Family Residential, said parcel also known as 320 N. Downing Street. |
| 8. Resolution PC 11-10 | A resolution requesting the zoning designation of parcel N44-250382 change from R-1 One-Family residential to R-3 Three-Family Residential, said parcel also known as 339 South Street. |

OTHER BUSINESS

PENDING BUSINESS UPDATE

None

ADJOURNMENT

- | | |
|----------------|-------------------------|
| 9. Adjournment | Adjourn Regular Session |
|----------------|-------------------------|

CITY OF PIQUA, OHIO
PLANNING COMMISSION MEETING MINUTES
TUESDAY, FEBRUARY 9, 2010 - 6:00 P.M.
MUNICIPAL GOVERNMENT COMPLEX - ADMINISTRATIVE CONFERENCE ROOM

CALL TO ORDER

6:00 P.M. – Chairman Spoltman called the meeting to order. Mr. Spoltman noted for the record the hearing of each item would be conducted according to a modified Roberts Rules of Order, more specifically as follows:

- A. Clerk to State the Agenda Item
- B. Staff Comments
- C. Applicant/Agent Comments
- D. Other Affected Parties Comments
- E. Board Member Comments and Questions
- F. Board To Take Action On The Item

ROLL CALL

Members Present: Jim Oda, Jean Franz, Mark Spoltman, and Mike Taylor
Members Absent: Brad Bubp
Staff Members: Chris Schmiesing, Becky Cool
Attendees: Stacie Francis, Chris Gray, and Dean Burch

MEETING MINUTES

Chairman Spoltman asked if there were additions, deletions or corrections to be made to the meeting minutes included in the agenda packet. Mr. Oda, made a motion to approve the February 9, 2010 Special Meeting minutes as submitted, and Mrs. Franz, seconded the motion. Mr. Oda, Aye; Mrs. Franz, Aye; Mr. Taylor, Aye; and Mr. Spoltman, Aye. A roll call vote resulted in a 4 -0 vote in supporting the motion to approve the meeting minutes as submitted.

NEW BUSINESS

1. PC-04-10

A Resolution requesting the continuation of a nonconforming retail sales and service use of the property /tenant space known as 1129 Park Avenue.

City Planner Chris Schmiesing stated the request is to authorize a change in the use of the premises to allow an existing nonconforming general merchandise retail sales and service use to be changed to a nonconforming personal service (photography studio) retail sales and service use. The subject premise also includes a separately occupied general merchandise use on the ground level, and a dwelling unit tenant space on the 2nd floor. There is limited on street parking available at the subject premise, which is located at the intersection of Washington Avenue and Park Avenue.

CITY OF PIQUA, OHIO
PLANNING COMMISSION MEETING MINUTES
TUESDAY, FEBRUARY 9, 2010 - 6:00 P.M.
MUNICIPAL GOVERNMENT COMPLEX - ADMINISTRATIVE CONFERENCE ROOM

The proposed use and use intensity is consistent with the past use activities that have been located at this premise, and is compatible with the surrounding land uses. The existing and proposed use is both retail sales and service type uses. The Comprehensive Plan is supportive of the positive reuse of existing structures and the redevelopment of vacant properties. Staff recommends approval of this request.

Applicant Stacie Francis, 1409 Nicklin Ave. came forward and stated she plans to open a photography studio with hours of operation from 9:00 – 9:00 Monday-Saturday, 1:00-7:00 on Sunday, and she would be the only employee at this time. Mr. Spoltman asked if the tenant space above her was occupied. Ms. Francis stated yes it is occupied at this time.

Mrs. Franz asked Ms. Francis if she inquired with the landlord as to the reason the previous tenant left. Ms. Francis stated no, she did not ask.

There was discussion on the number of anticipated customers the studio would have per day, and if nude photos were to be taken in the studio. Ms. Francis stated she hopes to have 3-4 customers per day, and no, there will definitely be no nudity taken in the studio. Mr. Oda stated he wanted Ms. Francis to know it was no reflection on her but was noted for the record. Ms. Francis stated she understood.

Mr. Oda stated he felt this an appropriate use of the structure, and type of activity that goes well in a neighborhood with a good reuse of the property in a residential area with the other mixed uses around. Mr. Spoltman stated he is not sure who the landlord is, but they did a very good job of fixing up the building.

Motion was made by Mr. Taylor to approve the request, seconded by Mr. Oda. Voice vote, Mr. Oda, Aye; Mr. Taylor, Aye; Mrs. Franz, Aye; and Mr. Spoltman, Aye. Nay, None. A voice vote resulted in a 4-0 vote to approve the request.

2. PC-05-10

A Resolution requesting the zoning designation of parcel N44-077996 change from R-2 to R-3, said parcel being portion of the property occupied by Upper Valley Community Church, 1400 Seidel Parkway.

Mr. Spoltman stated PC 05-10 and PC 06-10 have the same staff report information and proposed they both be read at this time and discussed, but that they be acted on separately.

Mr. Schmiesing this would change the zoning of two parcels owned by the Upper Valley Community Church. The two parcels are both contiguous to the primary tract of land on which the UVCC principal use improvements are located (1400 Seidel Parkway) and the use of the subject parcels is incidental to the primary tract. The zoning of the primary tract is R-3 while the zoning of one of the subjects lots is R-2 and the other is zoned R-1AA. The purpose of this request is to establish a uniform and consistent zoning designation of R-3 for all UVCC parcels situated at this location. The proposed zoning change will establish a zoning designation that is appropriate for the use activity found at this location and compatible with the surrounding land uses and zoning designations. Staff recommends approval of both of these requests.

CITY OF PIQUA, OHIO
PLANNING COMMISSION MEETING MINUTES
TUESDAY, FEBRUARY 9, 2010 - 6:00 P.M.
MUNICIPAL GOVERNMENT COMPLEX - ADMINISTRATIVE CONFERENCE ROOM

Mr. Schmiesing stated provided the City Commission approves the annexation, the property owner will come back with a replat survey to combine these three parcels into one tract of land, with one parcel number and one zoning designation.

Dean Burch, Upper Valley Community Church Board member came forward to answer any questions. Mr. Oda asked if the rezoning of the parcels was part of the long-term plan for the Church, and what the proposed use was for the land. Mr. Burch stated yes the rezoning was part of the long-term plan and the intended use is for a parking area. Mr. Spoltman stated he felt the R-3 zoning was a good fit for the area. Mr. Oda stated he felt this was a positive fit for the community.

Motion was made by Mr. Oda to approve the request, seconded by Mr. Taylor. Voice vote, Mr. Oda, Aye; Mr. Bubb, Aye; Mr. Taylor, Aye; Mrs. Franz, Aye; and Mr. Spoltman, Aye. Nay, None. A voice vote resulted in a 4-0 vote to approve the request.

3. PC-06-10

A Resolution requesting the zoning designation of parcel known as J27-032000 change from R-1AA to R-3, said parcel being portion of the property occupied by Upper Valley Community Church, 1400 Seidel Parkway.

This was previously discussed along with PC 05-10.

Motion was made by Mr. Oda to approve the request, seconded by Mr. Taylor. Voice vote, Mr. Oda, Aye; Mrs. Franz Aye; Mr. Taylor, Aye; and Mr. Spoltman, Aye. Nay, None. A voice vote resulted in a 4-0 vote to approve the request.

OTHER BUSINESS

2010 Meeting Schedule

Amend the 2010 Meeting Schedule

Mr. Schmiesing stated the Piqua City Commission has decided to move their meetings to the first and third Tuesday of the month, thus the reason to amend the Planning Commission Schedule.

Mr. Oda stated this was a reasonable compromise from the Planning Commission's standpoint.

Moved by Mr. Oda, seconded by Mr. Taylor to adopt the 2010 Piqua City Planning Commission Meeting Schedule as provided. Voice vote, Mr. Oda, Aye; Mr. Taylor, Aye; Mrs. Franz, Aye; and Mr. Spoltman, Aye. Nay, None. Motion resulted in a 4-0 voice vote to adopt the 2010 Piqua City Planning Commission Meeting Schedule as provided.

CITY OF PIQUA, OHIO
PLANNING COMMISSION MEETING MINUTES
TUESDAY, FEBRUARY 9, 2010 - 6:00 P.M.
MUNICIPAL GOVERNMENT COMPLEX - ADMINISTRATIVE CONFERENCE ROOM

Mr. Schmiesing introduced William Murphy, Assistant City Manager/Economic Development Director.

Mr. Murphy gave a brief Economic Development Overview. (See enclosed power point presentation).

Monthly Report

Mr. Schmiesing provided an update to the Planning Commission on legislative items, planning activities, permit issuances and other items of interest to the Planning Commission that occurred over the previous two months.

Mr. Schmiesing the Planning Commission to attend a public participation meeting scheduled for February 11, 2010 at 6:00 P.M. in the Municipal Government Complex to discuss the Redevelopment Opportunities Plan (REDO).

Mr. Schmiesing announced the new and improved staff report was now being implemented along with E-Gov Software and Permit Process.

ADJOURNMENT

With no further business to conduct it was moved and seconded that the regular meeting be adjourned. With all those present in favor the regular meeting was adjourned at 7:08 p.m.

Power Point Presentation

RESOLUTION No. PC 07-10

WHEREAS, AT&T, represented by GPD Associates, on behalf of Doug Knouff, owner of the subject parcel located in the City of Piqua, being in a district zoned I1 (Light Industrial), has submitted a request to authorize a cellular communication tower special use of parcel N44-100580, said parcel also known as 1703 Commerce Drive; and,

WHEREAS, a cellular communication tower is a special use in the I1 Light Industrial zoning designation in which the property is located; and,

WHEREAS, section 154.066 of the City of Piqua Code of Ordinances provides the procedure for authorizing the special use of a premises by approval of a special use permit request; and,

WHEREAS, the Planning Commission has studied the request, conducted a public hearing on the matter, and has established as fact that the proposed use:

- Will be compatible with the stated intent of the zoning district.
- Will not threaten the general health, safety, and welfare of the surrounding properties, and the adjacent property values will not be negatively affected.
- Is compatible with the general economic development policies of the City.
- Conforms to all other applicable codes and regulations of the city.

NOW THEREFORE BE IT RESOLVED, board member _____ hereby moves to _____ the request made, as described by this resolution, the testimony provided, and the documents attached hereto, the motion is seconded by board member _____, and the voting record on this motion is hereby recorded as follows.

	AYE	NAY	ABSTAIN	ABSENT
Mr. Jim Oda	<input type="checkbox"/>	<input type="checkbox"/>	<input type="checkbox"/>	<input type="checkbox"/>
Mr. Brad Bulp	<input type="checkbox"/>	<input type="checkbox"/>	<input type="checkbox"/>	<input type="checkbox"/>
Mr. Mike Taylor	<input type="checkbox"/>	<input type="checkbox"/>	<input type="checkbox"/>	<input type="checkbox"/>
Mrs. Jean Franz	<input type="checkbox"/>	<input type="checkbox"/>	<input type="checkbox"/>	<input type="checkbox"/>
Mr. Mark Spoltman	<input type="checkbox"/>	<input type="checkbox"/>	<input type="checkbox"/>	<input type="checkbox"/>

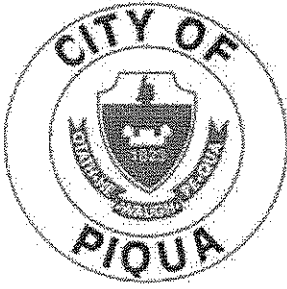

PLANNING AND ZONING

Christopher W. Schmiesing – City Planner
201 West Water Street • Piqua, Ohio 45356
(937) 778-2049 • FAX (937) 778-0809
E-Mail: cschmiesing@piquaoh.org

STAFF REPORT

Date: February 24, 2010
To: Planning Commission
From: Chris Schmiesing, City Planner
Subject: 1703 Commerce Cellular Communications Tower Special Use

GENERAL INFORMATION

Applicant: Ed Block of GPD Associates
Owner: Gerhardt Wholesale
Location: 1703 Commerce Drive
Zoning: I-1 (Light Industrial)
Land Use
Existing: Garden Supply Stores, Parking Lot, Loading and un-loading facility
Proposed: Garden Supply Stores, Parking Lot, Loading and un-loading facility;
Cellular/communications tower
Request: Authorization of special use to permit the proposed cellular tower communications use.

DISCUSSION/FINDINGS

This request is to authorize the addition of a cellular communications tower use to the uses currently found at the subject parcel. The premise is currently occupied by a Garden Supply Store, Parking Lot, and Loading and Un-loading facility. The information provided by the applicant indicates that the proposed 190 tall cellular communications tower will be situated to the rear of the subject tract, behind the nursery buildings and removed from the public right of way. The tower itself will be a monopole type assembly and initially include one provider antenna at the top of the structure with the option to add up to three other antennas to the tower in the future. The base of the tower will be setback 47.6 feet from the west and south lot lines and 152.4 from the east lot line. The setback to the north lot line will be over 600 feet. The tower will be situated in the center of a 100 foot by 100 foot "compound" that will be located adjacent to the south and west lot lines and enclosed by a 6 foot high chain link fence. Inside the compound there will be a small building for the placement of radio equipment and utility connections incidental to the cell tower operation. The entire area inside the fenced in compound will include a gravel surface. At the February 23, 2010 of the Board of Zoning Appeals the applicant's requests for variance related to the tower setback requirements and the gravel surface were considered and an exception to the code requirements was granted for both items.

With reference to existing nonstandard conditions found at this location, and concerning the potential aesthetic impact of the proposed tower, the applicant has included the following proposed improvements as part of the project to be constructed if authorized.

STAFF REPORT

Date: February 24, 2010

Subject: 1703 Commerce Cellular Communications Tower Special
Use

Page 2

- Installation of screening slats in the proposed fence to mitigate the view of the gravel surface and accessory building inside of the cell tower compound and barb wire at the top of the fence to discourage trespassing.
- Installation of fast growing pyramidal shaped trees around the perimeter of the compound to soften the aesthetic impact of the cell tower improvements and to screen the improvements from view from surrounding properties.
- Installation of Autumn Blaze maple trees along east lot line to buffer the adjacent retail sales and service uses and the Sunset Drive public right of way.
- Replacement of the majority of the existing gravel pavement located at the front of the existing nursery building with asphalt pavement.

COMPREHENSIVE PLAN

The goals, principles, objectives and strategies described in the Comprehensive Plan are supportive of permitting property uses that contribute positively to the neighborhood concerned and the community in general. The Plan recognizes the significant impact the built environment has on the aesthetics of the community and the overall community image and encourages the mitigation of any negative affects a proposed use or improvement may produce if left unattended.

CONCLUSION

The proposed cellular communications tower special use of this premise will be consistent and compatible with the land use types surrounding this property. The applicant's intent to improve a substantial portion of the nonstandard parking surface to bring it into conformance with the applicable standards, and the installation of screening/plantings to mitigate the visual impact of the tower, will ultimately result in a significant enhancement of the existing improvements found at this location.

RECOMMENDATION

Staff recommends that the Planning Commission **approve** the requested special use of the parcel with the following conditions:

1. The improvements are completed in accordance with the plans submitted and referenced as part of this request.
2. The applicant agree in writing to remove the tower, and all incidental and accessory features, to a depth of 4 feet below grade upon the structure becoming abandoned (discontinuance of the use of the structure for a period of more than 90 days).

STAFF REPORT

Date: February 24, 2010

Subject: 1703 Commerce Cellular Communications Tower Special Use

Page 3

VICINITY MAP



CITY OF PIQUA, OHIO

Application for Special Use Permit

1. Applicant's Name ED Block - AGENT FOR AT&T Phone 330-572-2192
GPD ASSOCIATES 520 S. MAINS ST. SUITE 2531
 Applicant's Address AKRON OH 44311
2. Owner's Name DOUG KNOWFF Phone 937-773-7673
 Owner's Address 1703 COMMERCE DRIVE
3. Type of legal interest held by applicant LEASE
4. Location of Special Use Permit request
 - A. Legal description (Inlot No. or attach legal description) WARRENTY DEED ATTACHED.
 - B. Address 1703 COMMERCE DRIVE
5. Existing zoning I-1 INDUSTRIAL
6. Existing usage GREENHOUSE
7. Proposed usage TELECOMMUNICATION SITE
8. Proposed special usage 190' MONOPOLE TOWER
9. No. of plot plans submitted (19 required UNLESS waived) INCLUDED

10. Describe the reason for the requested special use:

AT&T REQUIRES A TELECOMMUNICATION SITE (WITH 190' TOWER) FOR SIGNAL COVERAGE ON THE WEST SIDE OF PIQUA

I hereby certify that the proposed request is authorized by the "Owner of Record" and agree to conform to all applicable laws of the City of Piqua, Ohio.

Signature of Applicant [Signature] Date 1-26-10

X Signature of Owner [Signature] Date 1-25-10

Note: Both the owner and the applicant shall sign when application is made by someone other than the owner.

***** OFFICE USE ONLY *****

\$100.00 Fee Paid 100.00 Date Fee Paid 1-28-10

Receipt No. 186380 P.C. Res. No. _____



GPD ASSOCIATES
Engineers . Architects . Planners

2009249.39
January 26, 2010

The City of Piqua
210 West Water Street
Piqua OH 45356
Attn: Christopher Schmiesing
Planning and Zoning Supervisor

**RE: AT&T Cell Site (DAY2363 Piqua West)
1703 Commerce Drive, Piqua Ohio 45356
Zoning Submittal**

Dear Mr. Schmiesing,

AT&T Mobility, is proposing to build a telecommunication site on the property (address listed above) to provide seamless wireless coverage on the west side of Piqua. A monopole style tower of with a height of 190 feet is necessary to provide the best coverage for the area as well as allowing room for three (3) future carriers. A 100' x 100' lease area with a buffered, fenced compound will provide sufficient room for AT&T's unmanned, radio equipment shelter (11'-5"x 20' x 10' high) plus three (3) future carrier's shelters of equal or larger size.

As part of our submittal please note the following:

1. Ameritech Wireless Communications, now Cingular Wireless, dba AT&T Mobility, has Public Utility status (copy enclosed).
2. **The project will meet FCC emission standards.** - This site will be a 190' Monopole. By definition there will be no emissions exceeding the FCC maximum exposure limits due to the height of the transmit antennas. (RF Emissions checklist enclosed).
3. **Unique topographical features of the proposed parcel.** - Currently we have existing sites East and South of Piqua. This results in poor in building coverage on the W-NW part of Piqua. Also, the Great Miami River runs through Piqua which presents coverage problems due to elevation changes in this area. The proposed site location is on the West part of Piqua on a high elevation which helps with coverage. Also this location was chosen because it was located in an Industrial area of Piqua thus minimizing residential impact.
4. **Map showing existing gap in AT&T network coverage of this area versus the wireless receiving and transmitting coverage area of the proposed facility.** - See attached Coverage spreadsheets with maps.
5. **Radio frequency engineer's findings concerning minimum service requirements, optimum location, and minimum pole height necessary to remedy existing service deficiencies.** - Originally this site was targeted for 150' Monopole. When this height was analyzed it was shown from the propagation plots that the 190' CL gives us better coverage in the low elevation areas of Piqua and to the north. This higher center line will also help with our hand off out of Piqua to surrounding communities. The 190' monopole also gives others better Co-location opportunities but still is below the maximum height that would require it to have a beacon light for FAA purposes.

Enclosed please find the above listed information along with the following:

- Site and elevation plans (10 sets)
- Owner and Applicant signed BZA and Special Use forms
- Two checks in the amount of \$25.00 & \$100.00 for the application fees.

Please call with any questions, or if any additional information is needed, at (330) 572-2192.

Sincerely,

GPD Associates



Edward A. Block, P.E

RECEIVED

JAN 2 2010

CITY OF PIQUA
DEVELOPMENT OFFICE

RECEIVED

PUBLIC UTILITIES COMMISSION OF OHIO

SEP 23 1997

Certificate of Public Convenience and Necessity

AFFAIRS

Certificate Number:

90-5354

Issued Pursuant to Case Number(s):

97-823-CT-ACE

A Certificate of Public Convenience and Necessity to provide competitive telecommunication services in the State of Ohio pursuant to its tariff filed in Case No. 90-5354-CT-TRF is hereby granted to AMERITECH WIRELESS COMMUNICATIONS INC. DBA AMERITECH CELLULAR SERVICES, whose office or principal place of business is located at 2000 W. AMERITECH CENTER DRIVE #3H89D, HOFFMAN ESTATES, ILLINOIS 60195-5000.

This Certificate is revocable if all of the conditions set forth in the aforementioned case(s) are not met.

Subject to all rules and regulations of the Commission, now existing or hereafter promulgated.

Witness the seal of the Commission affixed at Columbus, Ohio.

Dated: Sept. 15, 1997



By Order of

PUBLIC UTILITIES COMMISSION OF OHIO

Daisy L. Crockron

Gary E. Vigorito, Secretary

Daisy L. Crockron, Acting Secretary

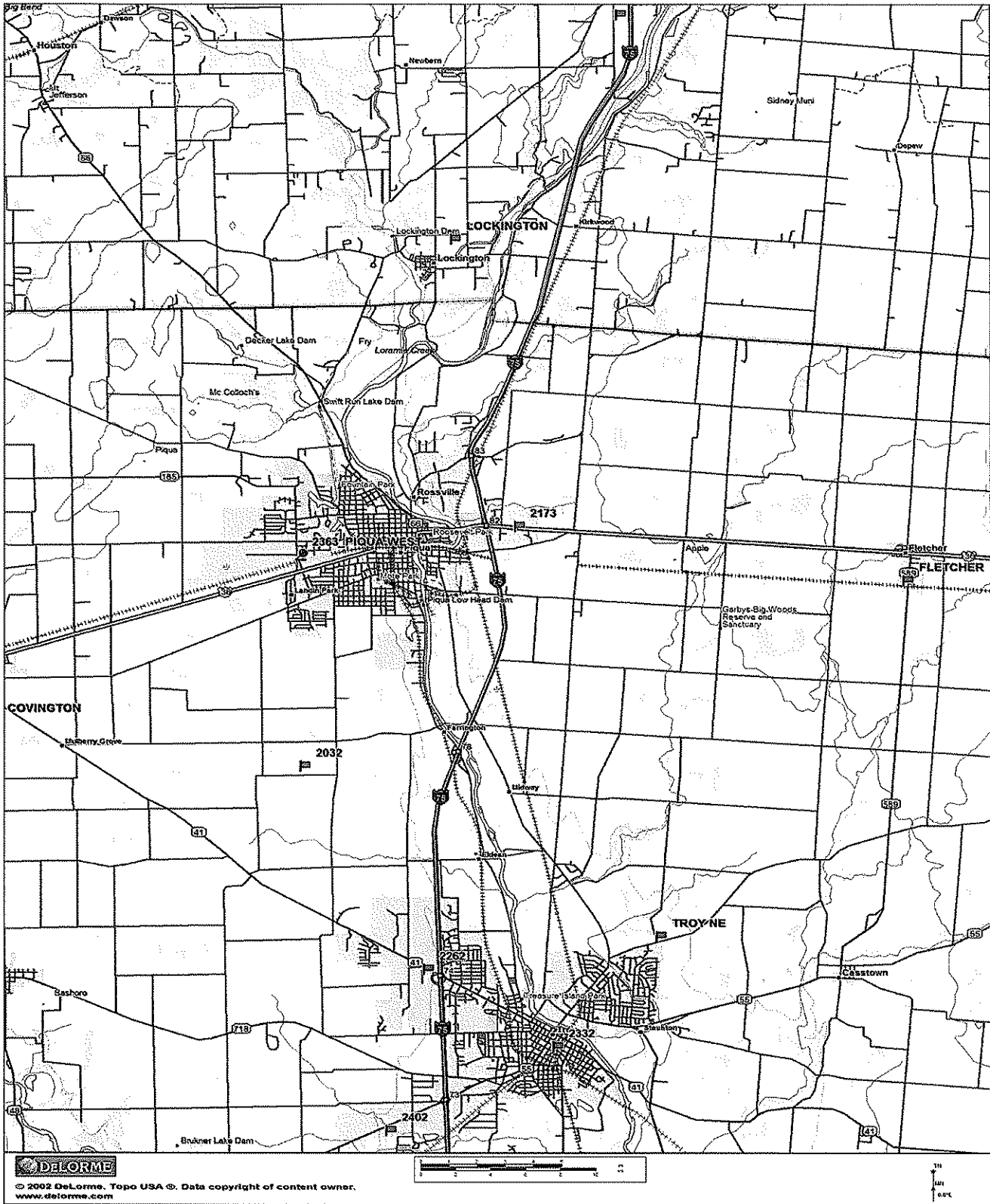

RED FLAGS DENOTE EXISTING SITES, BLUE PIN - PROPOSED

CLOSEST EXISTING SITES

2173	DT PIQUA	-84.21297	40.14931	STATE ROU	PIQUA	OH	45356
2032	PIQUA	-84.2682	40.09681	3455 WASHI	COVINGTON	OH	49318

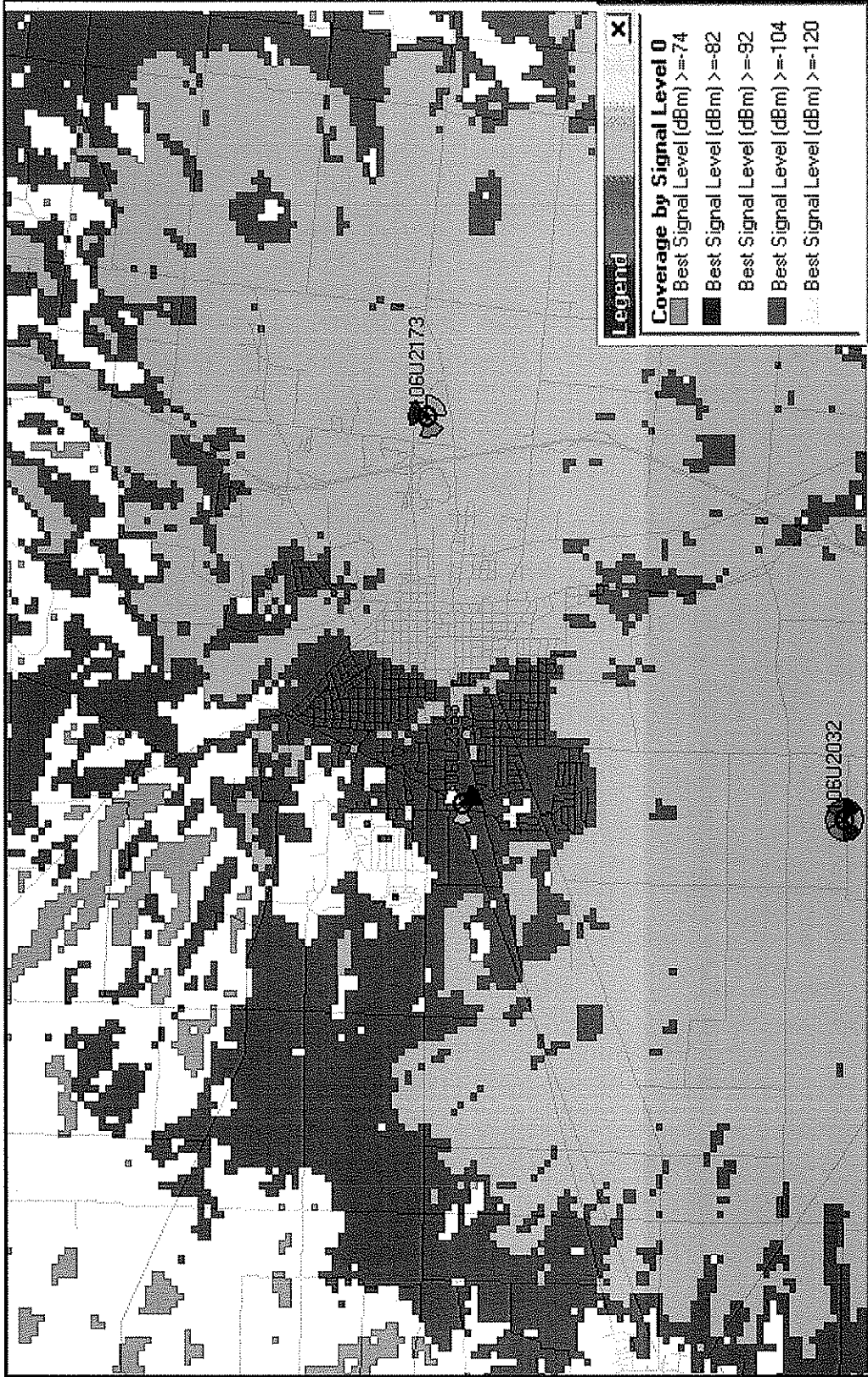

Legend X

Coverage by Signal Level 0

- Best Signal Level (dBm) >=-74
- Best Signal Level (dBm) >=-82
- Best Signal Level (dBm) >=-92
- Best Signal Level (dBm) >=-104
- Best Signal Level (dBm) >=-120

EXISTING COVERAGE

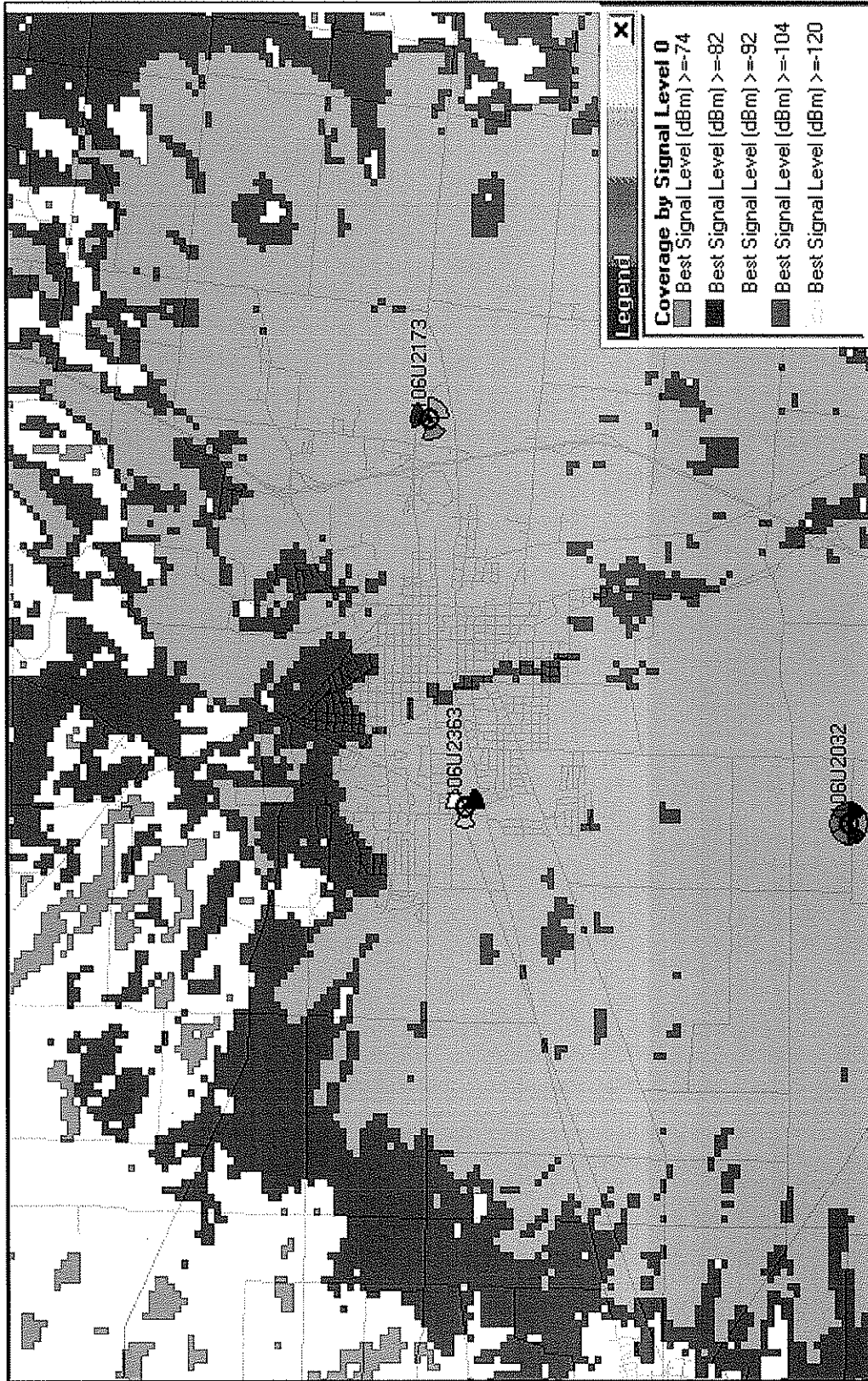

PROPOSED COVERAGE WITH A 150' TOWER

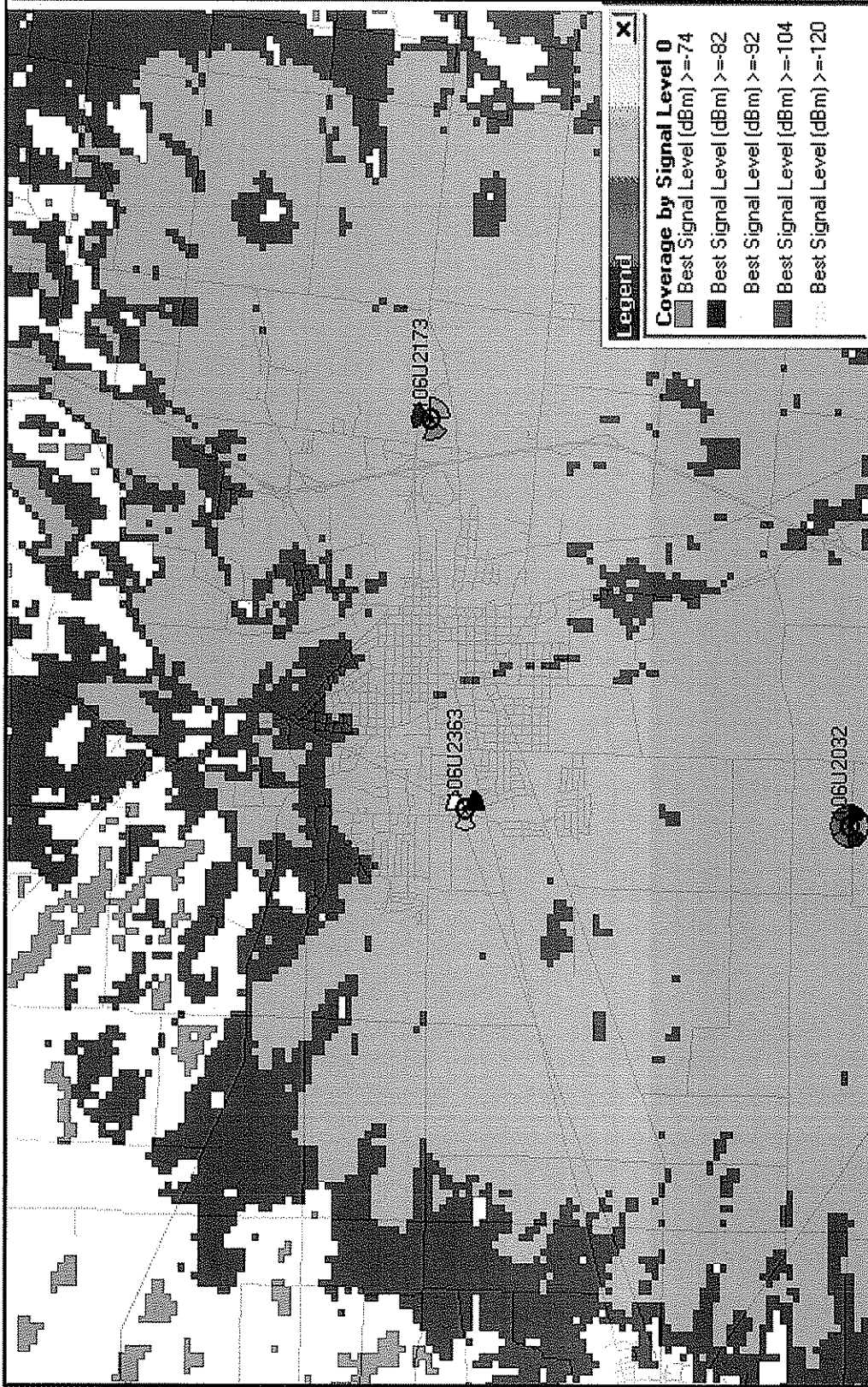

PROPOSED COVERAGE WITH A 190' TOWER

Checklist for Local Government To Determine Whether a Facility is Categorically Excluded

(Taken from the FCC's "A Local Government Official's Guide to Transmitting Antenna RF Emission Safety: Rules, Procedures, and Practical Guidance")

Purpose: The FCC has determined that many wireless facilities are unlikely to cause human exposures in excess of RF exposure guidelines. Operators of those facilities are exempt from routinely having to determine their compliance. These facilities are termed "categorically excluded." Section 1.1307(b)(1) of the Commission's rules defines those categorically excluded facilities. This checklist will assist state and local government agencies in identifying those wireless facilities that are categorically excluded, and thus are highly unlikely to cause exposure in excess of the FCC's guidelines. Provision of the information identified on this checklist may also assist FCC staff in evaluation any inquiry regarding a facility's compliance with the RF exposure guidelines.

BACKGROUND INFORMATION

1. Facility Operator's Legal Name: AT&T Mobility
2. Facility Operator's Mailing Address: 485 Metro Place South, Dublin, OH 43017
3. Facility Operator's Contact Name/Title: Gale Hirst / RF Engineer
4. Facility Operator's Office Telephone: (614) 530-1056
5. Facility Operator's Fax: _____
6. Facility Name: DAY-2363, AAVC, PIQUA WEST
7. Facility Address: _____
8. Facility City/Community: Piqua
9. Facility State and Zip Code: Miami County, OH 45356

EVALUATION OF CATEGORICAL EXCLUSION

- 10. Licensed Radio Service (see attached Table 1): Cellular Radiotelephone Service
- 11. Structure Type (free-standing or building/roof-mounted): free-standing
- 12. Antenna Type [omni-directional or directional (includes sectored)]: directional
- 13. Height above ground of the lowest point of the antenna (in meters): 57.91 (Proposed)
- 14. Check if all of the following are true:
 - (a) This facility will be operated in the Multipoint Distribution Service, Paging and Radiotelephone Service, Cellular Radiotelephone Service, Narrowband or Broadband Personal Communications Service, Private Land Mobile Radio Services Paging Operations, Private Land Mobile Radio Service Specialized Mobile Radio, Local Multipoint Distribution Service, or service regulated under Part 74, Subpart I (see question 10).
 - (b) This facility will not be mounted on a building (see question 11).
 - (c) The lowest point of the antenna will be at least 10 meters above the ground (see question 13).

If box 14 is checked, this facility is categorically excluded and is unlikely to cause exposure in excess of the FCC's guidelines. The remainder of the checklist need not be completed. If box 14 is not checked and the facility is not mounted on a building, continue to question 15.

- 15. Enter the power threshold for categorical exclusion for this service from the attached Table 1 in watts ERP or EIRP* (note: $EIRP = (1.64) \times ERP$): _____
- 16. Enter the total number of channels if this will be an omni-directional antenna, or the maximum number of channels in any sector if this will be a sectored antenna: _____
- 17. Enter the ERP or EIRP per channel (using the same units as in question 17): _____
- 18. Multiply answer 16 by answer 17: _____
- 19. Is the answer to question 18 less than or equal to the value from question 15 (yes or no)? _____

If the answer to question 19 is YES, this facility is categorically excluded. It is unlikely to cause exposure in excess of the FCC's guidelines.

If the answer to question 19 is NO, this facility is not categorically excluded. Further investigation may be appropriate to verify whether the facility may cause exposure in excess of the FCC's guidelines.

"ERP" means "effective radiated power" and "EIRP" means "effective isotropic radiated power"

All information set forth is true, accurate, and complete

Signed: Gale K. Hurst

Date: 1/26/10

Title: RF Engineer

GENERAL WARRANTY DEED ^{BY 678 BY 834} ~~BY 678 BY 834~~ - O.R.C. SECTION 5302.05)
KNOW ALL MEN BY THESE PRESENTS
 Gerhart Wholesale Distributors, Inc., a Corporation
 incorporated under the laws of the State of Ohio, Grantor, of Miami
 County, Ohio, grants with general warranty covenants to Douglas L.
 Kneuff (an undivided 51% interest) and Cathryn A. Kneuff (an
 undivided 49% interest), husband and wife, for their joint lives,
 remainder to the survivor of them, whose tax-mailing address is 10
 Orchard, Piqua, Ohio 45356, the following real property:

Situate in the City of Piqua, County of Miami and State
 of Ohio, to-wit:
 Being a 3.011-acre tract, Part Parcel 313, in the City of
 Piqua, Ohio, and further bounded and described as
 follows: Beginning at the southeast corner of Oakwood 313
 and on the west right-of-way line of Sunset Drive; thence
 south 68 deg. 44' 00" West for 190.93 ft. to a 1/4" iron
 stake; thence the true place of beginning; thence continuing
 south 18 deg. 44' 00" West for 210.14 ft. to a capped
 iron pin; thence North 63 deg. 23' 00" West for
 687.38 ft. to a 1/4" iron pin found; thence North 86 deg. 37'
 00" East for 300.00 feet to a point; thence South 93 deg.
 24' 00" East for 623.46 ft. to the iron pin marking the
 place of beginning. Containing a total of 3.011-acres and
 subject to all legal easements, rights-of-way and
 restrictions of record.
 According to a survey performed by Michael S. Coeatt,
 Professional Surveyor No. 6561, 615 East Dakota Street,
 Troy, Ohio 45373, according to surveys filed in Vol. 94,
 Page 144 and Vol. 10, Page 150 of the Miami County
 Engineer's Record of Lot Surveys.

SAVING AND EXCEPTING the taxes and assessments due and
 payable in June, 1957, and thereafter, all of which the
 grantee herein agrees to pay. The grantee
 also agrees to accept the Property subject to all
 easements, restrictions and covenants of record.

Prior Instrument Reference: Volume 664, Page 861, of the Deed
 Records of Miami County, Ohio.

In Witness Whereof, the said Gerhart Wholesale Distributors,
 Inc. by Douglas L. Kneuff, its President/Treasurer, and Cathryn A.
 Kneuff, its Vice President/Secretary, has hereunto set its hand
 this 19th day of June, 1957.

SIGNED IN THE PRESENCE OF:

D. M. Smith
Ann Ellen Smith

GERHART WHOLESALERS
 DISTRIBUTORS, INC.
 Douglas L. Kneuff
 its President/Treasurer,
 and Cathryn A. Kneuff,
 its Vice President/Secretary

TRANSFERRED	
THIS INSTRUMENT WAS FILED IN THE PUBLIC RECORDS OF MIAMI COUNTY, OHIO	
JUN 20 1957	
Tax	\$165.00
REC 31354	100
REC 31354	100
REC 31354	100

RECORDED
 JUN 20 1957

STATE OF OHIO, COUNTY OF MIAMI, SS:

Before me, a Notary Public in and for said County and State, personally appeared Gerhart Engelmann, District Attorney, by Benjamin L. Knouff, its President/Treasurer, and Steven A. Spout, its Vice President/Secretary, who acknowledged that they did sign the foregoing instrument and that the same was the free and deed of said corporation and the free act and deed of themselves as such officers.

Witness my official signature and seal this 23rd day of June, 1997.



Notary Public - State of Ohio
My Comm. Exp: _____

2465 Ohio Ave. Columbus, OH 43221
Notary Public - State of Ohio

THIS INSTRUMENT PREPARED BY: Dale G. Davis, of McCulloch, Polger, Rice & Gutmann Co., LPA, Attorneys at Law, Piqua, Ohio.

RECEIVED
JUN 23 1997
11/1/00

21927

TO

678

RECEIVED

Medallion Trust For B. G. W. Co., L.P.A.
ATTORNEYS AT LAW
1700 Linn Street, Suite 400
Piqua, Ohio 45352

Data For Parcel N44-100580

Base Land Valuation Sales Sketch Tax Improvements Additions Residential Agricultural Commercial Comments

Base Data

Parcel: N44-100580
 Owner: KNOUFF DOUGLAS L & CATHRYN A
 Address: 1703 COMMERCE DR



Tax Mailing Address

Tax Mailing Name: KNOUFF DOUGLAS L
 Address: PO BOX 1674
 City State Zip: PIQUA OH 45356

Owner Address

Owner Name: KNOUFF DOUGLAS L
 Address: 1703 COMMERCE DR
 City State Zip: PIQUA OH 45356

Geographic

City: CITY OF PIQUA
 Township:
 School District: PIQUA CSD

Legal

Legal Acres:	3.011	Homestead Reduction:	NO
Legal Description:	OUT LOT 313 N44-2S5750 ABATE TY 1997 EXP TY 2011	2.5% Reduction:	NO
Land Use:	399 - OTHER INDUSTRIAL STRUCTURES	Foreclosure:	NA
Neighborhood:	02100	Board of Revision:	NO
Number Of Cards:	1	New Construction:	NA
Annual Tax (Does not include delinquencies.):	\$1,640.88	Divided Property:	NA
Map Number:	080513.3-02-005-00	Routing Number:	080513.3-02-005-00

Notes

Notes:

Copyright ©2007 Digital Data Technologies, Inc.
 CAMA database last updated 10/30/2009 11:51:07 PM.

<http://www.miamicountyauditor.org/Data.aspx?ParcelID=N44-100580>

11/2/2009

Tax Documentation

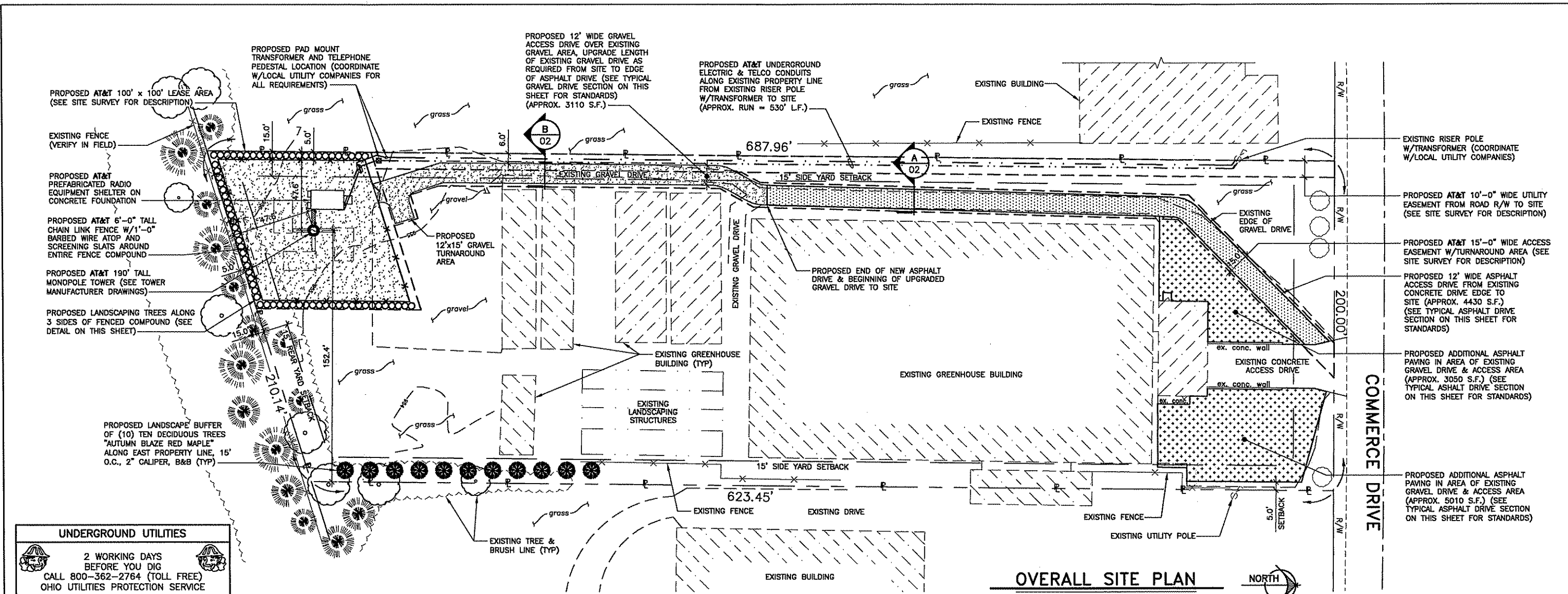

UNDERGROUND UTILITIES

2 WORKING DAYS BEFORE YOU DIG
CALL 800-362-2764 (TOLL FREE)
OHIO UTILITIES PROTECTION SERVICE

NON-MEMBERS MUST BE CALLED DIRECTLY

NOTE:
CONTRACTOR SHALL GUARANTEE ALL NEWLY PLANTED TREES FOR A MINIMUM OF 1 YEAR AFTER COMPLETION OF PROJECT. GUARANTEE SHALL BE FOR FULL REPLACEMENT OF LOST PLANTS.

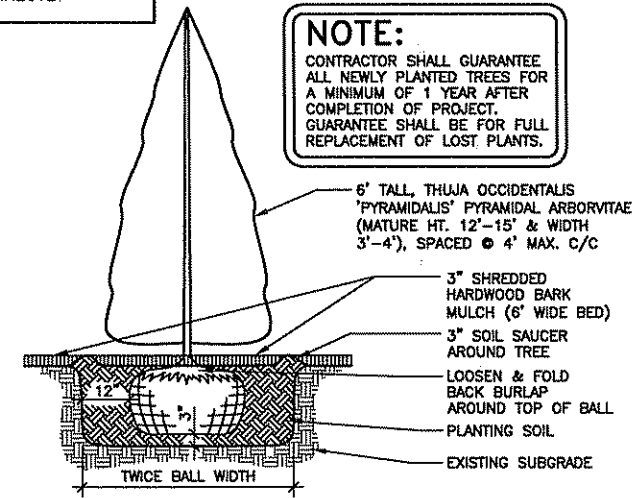

LANDSCAPE TREE DETAIL

SCALE: N. T. S.
NOTE: TOTAL OF 70

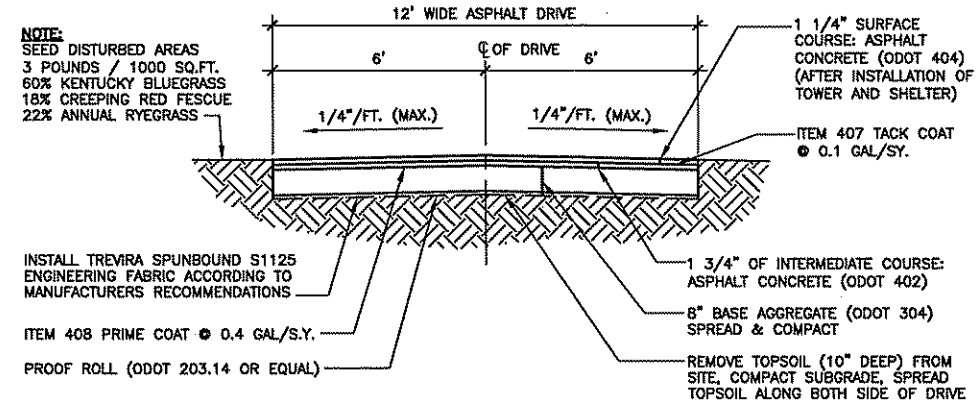

TYPICAL ASPHALT DRIVE SECTION

SCALE: N. T. S.

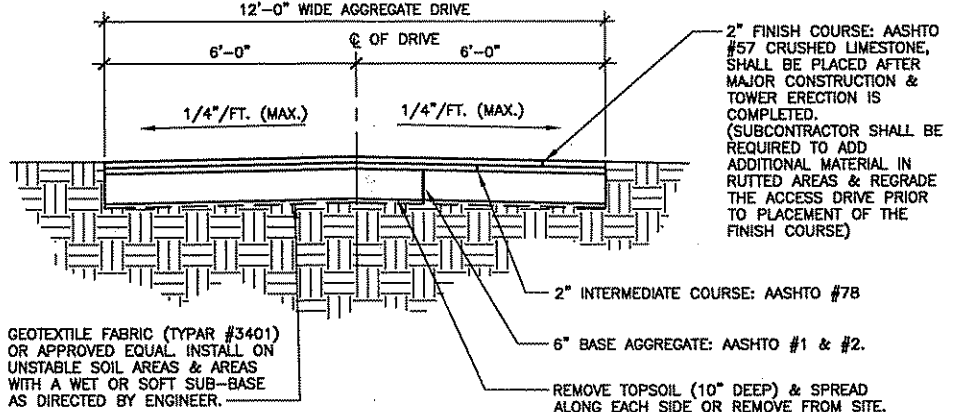

TYPICAL GRAVEL DRIVE SECTION

SCALE: N. T. S.

GPD JOB #2009249.39

BLACK & VEATCH
485 METRO PLACE SOUTH
SUITE 500
DUBLIN, OHIO 43017

GLAUS PYLE SCHOMER BURNS & DEHAVEN INC.
GPD ASSOCIATES
520 South Main Street, Suite 2531 Akron, Ohio 44311
330-572-2100, Fax 330-572-2101

DAY2363
PIQUA WEST
1703 COMMERCE DRIVE
PIQUA, OHIO 45356

NO.	DATE	REVISIONS	BY	CHK	APP'D
A	01/27/10	PRELIMINARY PLANS ISSUED FOR REVIEW	BB	EAB	EAB
DESIGNED BY: BB DRAWN BY: BB DRAWN DATE: 01/11/10 SCALE: AS SHOWN					

AT&T Mobility
OVERALL SITE PLAN, SECTIONS & DETAILS
DRAWING NUMBER: DAY2363-02
REV: A

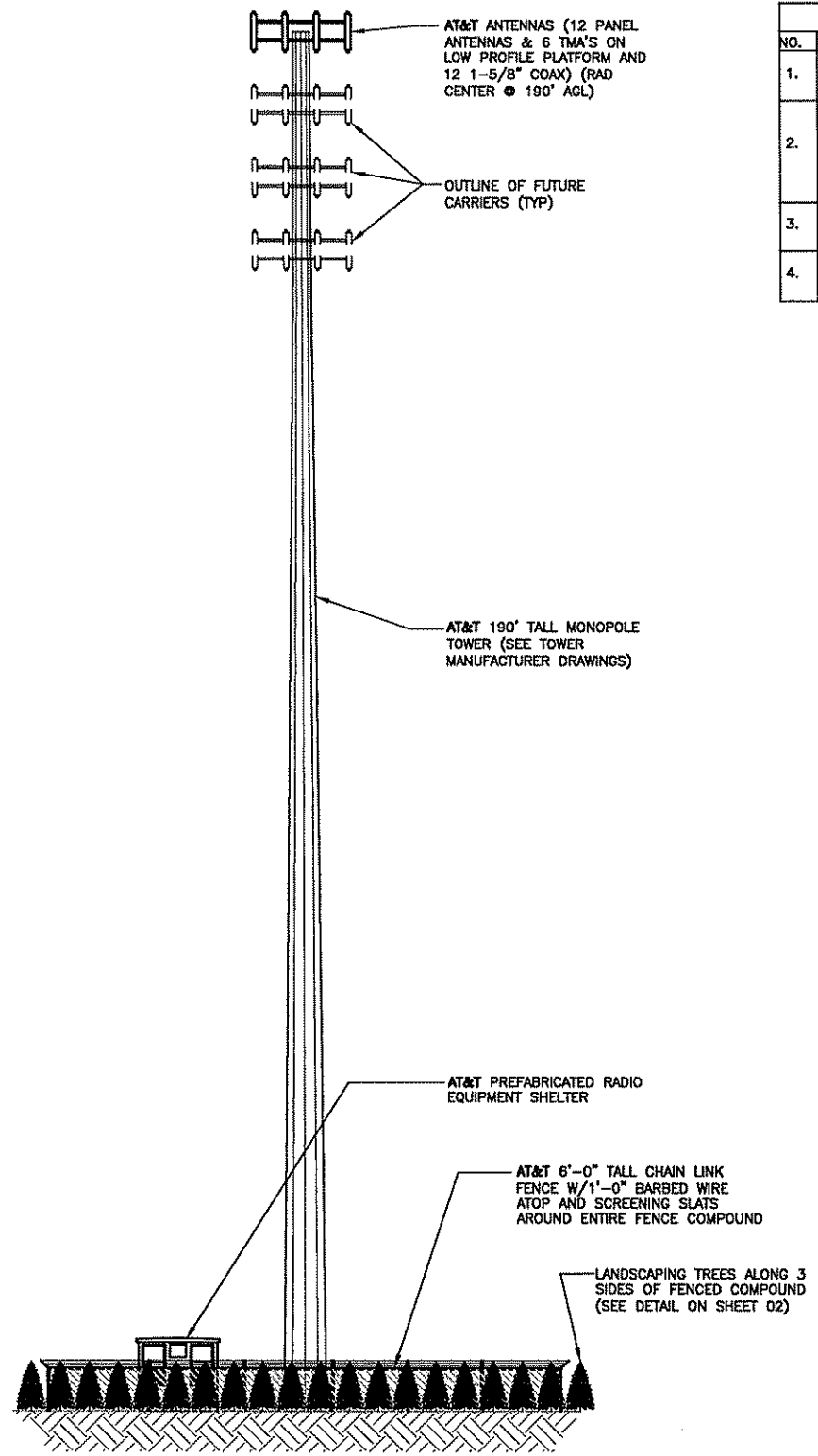

TOWER ELEVATION
SCALE: N. T. S.

CABLE MARKING LOCATIONS TABLE			
NO.	TAPE	TAG	LOCATIONS
1.	X		EACH TOP-JUMPER SHALL BE COLOR CODED WITH (1) SET OF 3" WIDE BANDS.
2.	X		EACH MAIN COAX SHALL BE COLOR CODED WITH (1) SET OF 3" WIDE BANDS NEAR THE TOP-JUMPER CONNECTION AND WITH (1) SET OF 3/4" WIDE COLOR BANDS JUST PRIOR TO ENTERING THE BTS OR TRANSMITTER BUILDING.
3.	X		ALL BOTTOM JUMPERS SHALL BE COLOR CODED WITH (1) SET OF 3/4" WIDE BANDS ON EACH END OF THE BOTTOM JUMPER.
4.	*	*	ALL BOTTOM JUMPERS SHALL BE COLOR CODED WITH (1) SET OF 3/4" WIDE BANDS ON EACH END OF THE BOTTOM JUMPER.

(* -- DENOTES TAG OR TAPE.)

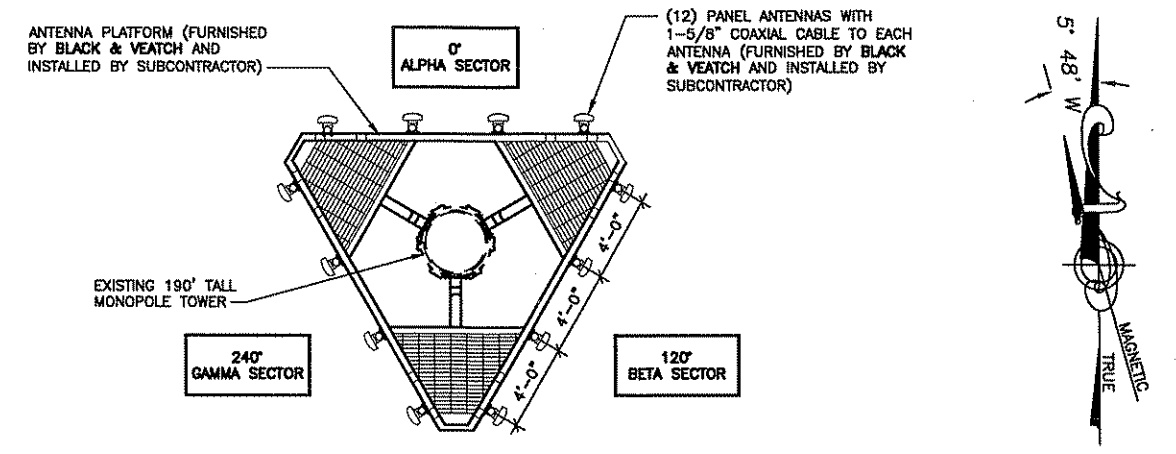

ANTENNA PLAN
N. T. S.

NOTE:
SUBCONTRACTOR SHALL CHECK WITH BLACK & VEATCH PRIOR TO BIDDING AND CONSTRUCTION TO VERIFY INFORMATION ON THIS SHEET IS CURRENT.

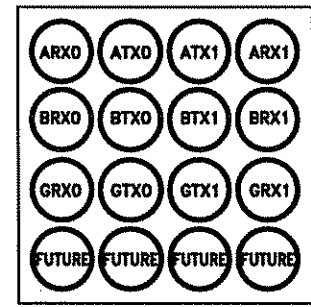

WAVEGUIDE ENTRY PORT SCHEDULE
EXTERIOR VIEW

- PART 1 -- MATERIALS**
- A. ANTENNAS**
1. INSTALLATION OF ANTENNAS AND ASSOCIATED MOUNTING HARDWARE PER MANUFACTURER'S RECOMMENDED STANDARDS OF PRACTICE.
- ANTENNA AND COAXIAL CABLE GROUNDING**
- A. THE OMNI OR DIRECTIONAL ANTENNA COAXIAL CABLES SHALL HAVE, AS A MINIMUM, FOUR (4) GROUND KITS INSTALLED. ONE (1) AT THE ANTENNA JUMPER CONNECTION WITH GROUND KITS CONNECTED TO THE TOWER ASSEMBLY, ONE (1) AT THE LAST VERTICAL TO HORIZONTAL TRANSITION PRIOR TO THE EQUIPMENT LOCATION, ONE (1) AT OUTSIDE OF PREFABRICATED EQUIPMENT SHELTER AND ONE (1) AT THE INSIDE OF THE PREFABRICATED EQUIPMENT SHELTER.
- COAXIAL CABLE IDENTIFICATION**
- A. TO PROVIDE EASY IDENTIFICATION AND UNIFORM MARKING OF ANTENNA CABLING, MARKINGS SHALL BE MADE BY USE OF COLORED, 3/4" WIDE TAPE (TYPE 35 AS MANUFACTURED BY 3M CORP.), AFFIXED AT THREE PLACES ON THE COAX CABLE RUN.
- B. COLOR CODE COAXIAL CABLES AS SHOWN ON THIS SHEET.
- C. COLOR CODE AND TAG ALL CABLES AT THREE (3) LOCATIONS.
- ANTENNA CONNECTIONS
 - OUTSIDE WAVE GUIDE ENTRY PORT.
 - INSIDE WAVE GUIDE ENTRY PORT.
- TESTING**
- A. SEE RF SWEEP SECTION OF SPECIFICATIONS IN CONSTRUCTION DOCUMENTS.
- B. PROVIDE FOUR (4) COPIES OF THE ANTENNA AND COAX SWEEP TEST RESULTS TO THE OWNERS REP. SWEEP TESTS SHALL BE PERFORMED ACCORDING TO AT&T STANDARDS.
- C. MATERIALS**
- A. EXCEPT AS OTHERWISE INDICATED, PROVIDE ELECTRICAL GROUNDING AND BONDING SYSTEMS INDICATED; WITH ASSEMBLY OF MATERIALS, INCLUDING, BUT NOT LIMITED TO, GROUNDING ELECTRODES, BONDING JUMPER BRAID, AND ADDITIONAL ACCESSORIES NEEDED FOR A COMPLETE INSTALLATION. WHERE MATERIALS OR COMPONENTS ARE NOT INDICATED, PROVIDE PRODUCTS WHICH COMPLY WITH NEC, UL, AND IEEE REQUIREMENTS AND WITH ESTABLISHED INDUSTRY STANDARDS FOR THOSE APPLICATIONS INDICATED.
- B. GROUND CONDUCTORS SHALL BE STANDARD TINNED SOLID BARE COPPER AND SIZE INDICATED ON DRAWINGS. MINIMUM BENDING RADIUS SHALL BE MAINTAINED ACCORDING TO NEC.
- C. SUBSTITUTIONS OF MATERIAL AND EQUIPMENT WILL BE PERMITTED ONLY BY WRITTEN APPROVAL OF BLACK & VEATCH TELECOMMUNICATIONS.

GPD JOB #2009249.39

BLACK & VEATCH
485 METRO PLACE SOUTH
SUITE 500
DUBLIN, OHIO 43017

GLAUS PYLE SCHOMER BURNS & DEHAVEN INC.
GPD ASSOCIATES
520 South Main Street, Suite 2531 Akron, Ohio 44311
330-572-2100, Fax 330-572-2101

DAY2363
PIQUA WEST
1703 COMMERCE DRIVE
PIQUA, OHIO 45356

NO.	DATE	REVISIONS	BY	CHK	APP'D
A	01/27/10	PRELIMINARY PLANS ISSUED FOR REVIEW	BB	EAB	EAB
DESIGNED BY: BB DRAWN BY: BB DRAWN DATE: 01/11/10 SCALE: AS SHOWN					

AT&T Mobility
TOWER ELEVATION, ANTENNA PLAN
& SCHEDULE/COAX IDENTIFICATION
DRAWING NUMBER
DAY2363-04
REV A

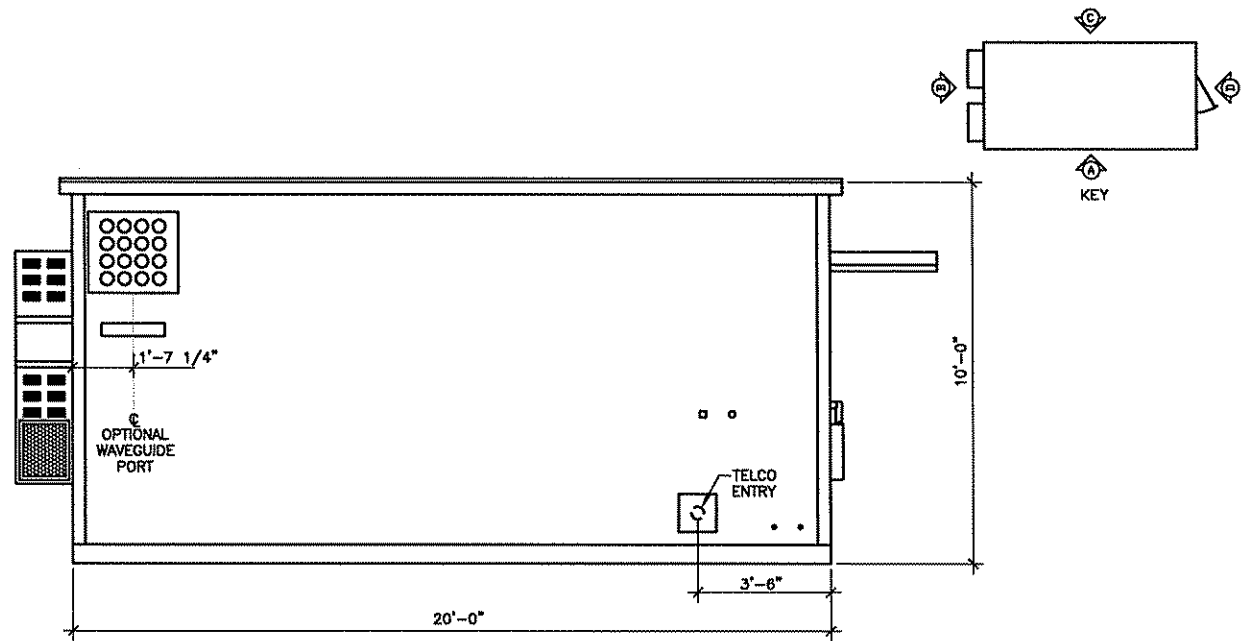

FIBREBOND BUILDING ELEVATION 'A'
SCALE: N. T. S.

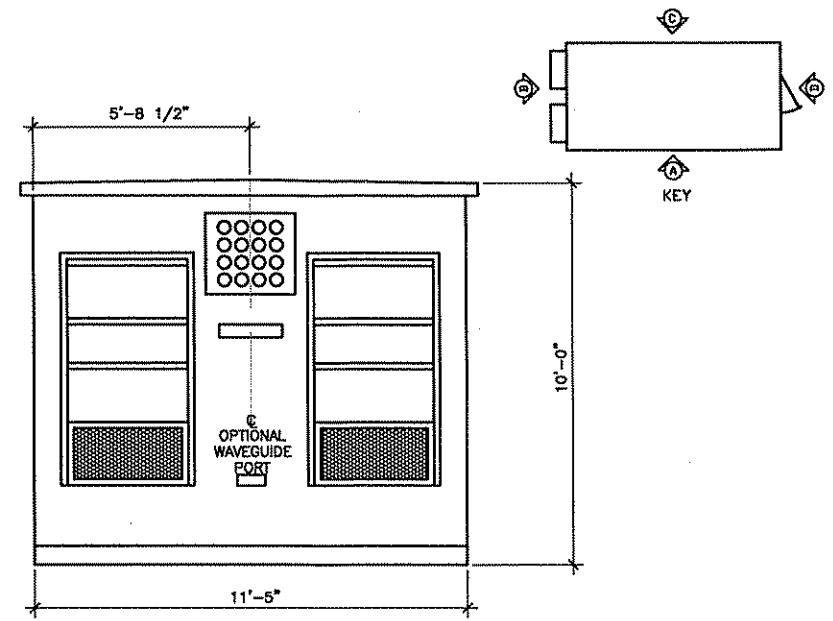

FIBREBOND BUILDING ELEVATION 'B'
SCALE: N. T. S.

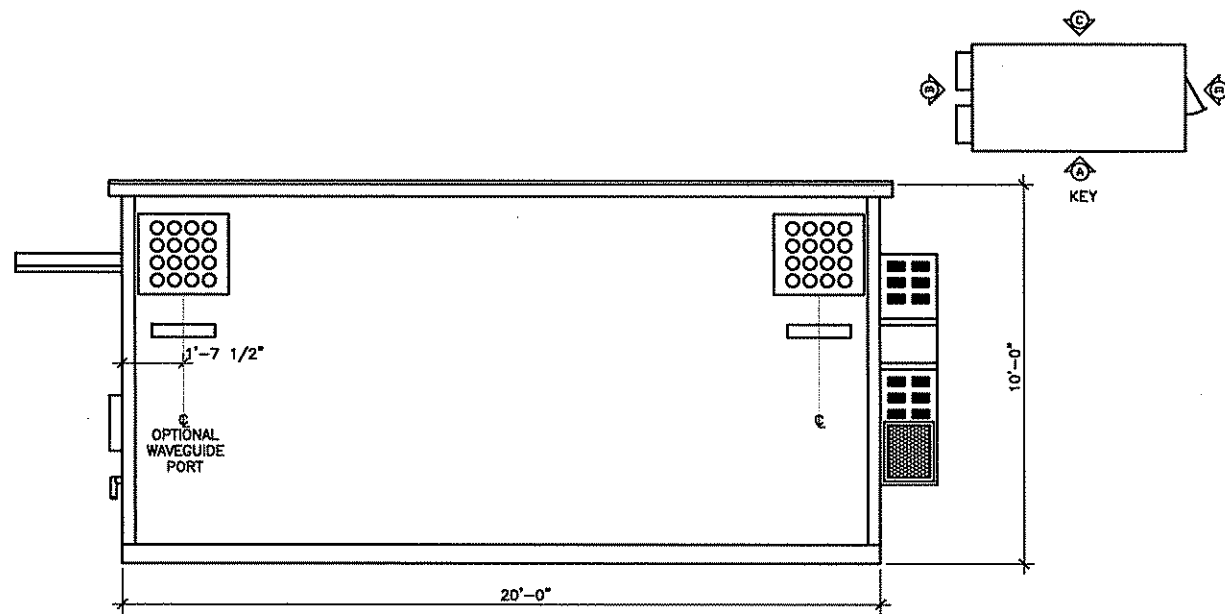

FIBREBOND BUILDING ELEVATION 'C'
SCALE: N. T. S.

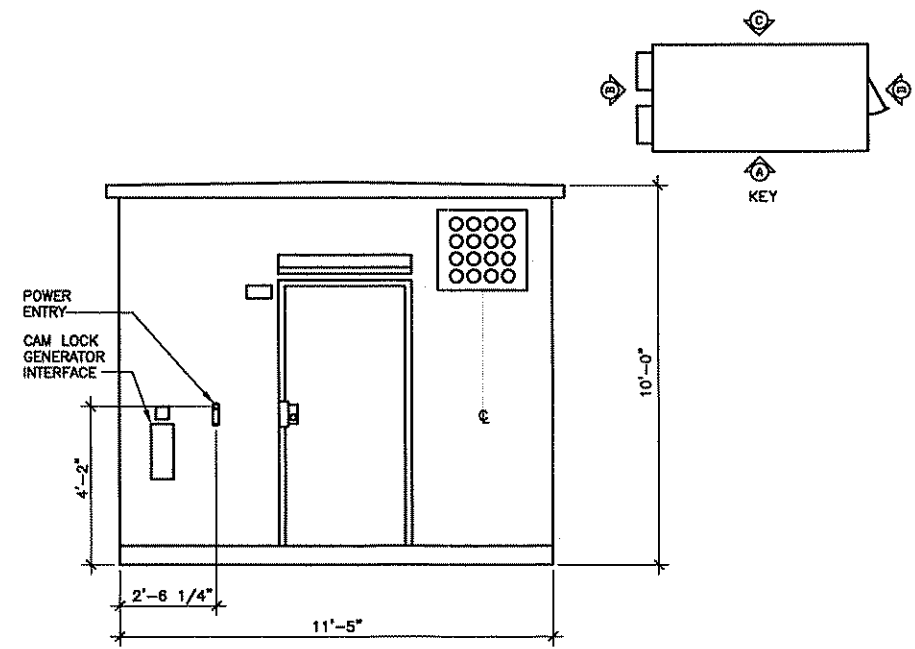

FIBREBOND BUILDING ELEVATION 'D'
SCALE: N. T. S.

GPD JOB #2009249.39

BLACK & VEATCH
485 METRO PLACE SOUTH
SUITE 500
DUBLIN, OHIO 43017

GLAUS PYLE SCHOMER BURNS & DEHAVEN INC.
GPD ASSOCIATES
520 South Main Street, Suite 2531 Akron, Ohio 44311
330-572-2100, Fax 330-572-2101

DAY2363
PIQUA WEST
1703 COMMERCE DRIVE
PIQUA, OHIO 45356

NO.	DATE	REVISIONS	BY	CHK	APP'D
A	01/27/10	PRELIMINARY PLANS ISSUED FOR REVIEW	BB	EAB	EAB
DESIGNED BY: BB			DRAWN BY: BB		
DRAWN DATE: 12/29/09			SCALE: AS SHOWN		

AT&T Mobility
SHELTER ELEVATIONS
DRAWING NUMBER
DAY2363-06

ZONING MAP



Zoning		R3-Multi-Family Residential
		R2-Two-Family Residential
		R1AA-One-Family Residential
		R1A-One-Family Residential
		R1-One-Family Residential
		OS-Open Space
		I2-Heavy Industrial
		I1-Light Industrial
		F-Floodplain
		CBD-Central Business District
		B - Business
	Buffer layer	
Parcels		Parcels (auto-on)
Transportation	Abc StreetNames	
		Railroad
		Street Centerlines
		Major Highways
Natural Features		Water Bodies
		Redline

RESOLUTION No. PC 08-10

WHEREAS, Robert Brown, on behalf of Rick James, owner of the subject parcel located in the City of Piqua, being in a district zoned B (General Business), has submitted a request to authorize an automobile repair, painting and body shop special use of parcel N44-073740, said parcel also known as 8620 N CR-25A; and,

WHEREAS, an automobile repair, painting and body shop is a special use in the B General Business zoning designation in which the property is located; and,

WHEREAS, section 154.066 of the City of Piqua Code of Ordinances provides the procedure for authorizing the special use of a premises by approval of a special use permit request; and,

WHEREAS, the Planning Commission has studied the request, conducted a public hearing on the matter, and has established as fact that the proposed use:

- Will be compatible with the stated intent of the zoning district.
- Will not threaten the general health, safety, and welfare of the surrounding properties, and the adjacent property values will not be negatively affected.
- Is compatible with the general economic development policies of the City.
- Conforms to all other applicable codes and regulations of the city.

NOW THEREFORE BE IT RESOLVED, board member _____ hereby moves to _____ the request made, as described by this resolution, the testimony provided, and the documents attached hereto, the motion is seconded by board member _____, and the voting record on this motion is hereby recorded as follows.

	AYE	NAY	ABSTAIN	ABSENT
Mr. Jim Oda	<input type="checkbox"/>	<input type="checkbox"/>	<input type="checkbox"/>	<input type="checkbox"/>
Mr. Brad Bulp	<input type="checkbox"/>	<input type="checkbox"/>	<input type="checkbox"/>	<input type="checkbox"/>
Mr. Mike Taylor	<input type="checkbox"/>	<input type="checkbox"/>	<input type="checkbox"/>	<input type="checkbox"/>
Mrs. Jean Franz	<input type="checkbox"/>	<input type="checkbox"/>	<input type="checkbox"/>	<input type="checkbox"/>
Mr. Mark Spoltman	<input type="checkbox"/>	<input type="checkbox"/>	<input type="checkbox"/>	<input type="checkbox"/>

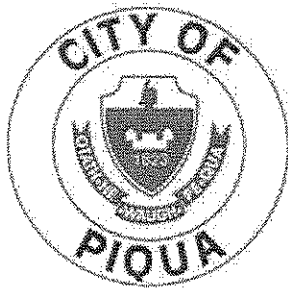

PLANNING AND ZONING

Christopher W. Schmiesing – City Planner
201 West Water Street • Piqua, Ohio 45356
(937) 778-2049 • FAX (937) 778-0809
E-Mail: cschmiesing@piquaoh.org

STAFF REPORT

Date: February 24, 2010
To: Planning Commission Members
From: Chris Schmiesing, City Planner
Subject: 8620 N CR-25A Automobile Repair, Painting and Body Shop Special Use

GENERAL INFORMATION

Applicant: Robert Brown
Owner: Rick James
Location: 8620 N CR-25A
Zoning: Existing – B General Business
Land Use
Existing: Vacant vehicle sales, rental and service
Proposed: Automobile repair, painting and body shop
Request: Authorization of special use to permit the proposed automobile repair, painting and body shop use.

DISCUSSION/FINDINGS

This request is to authorize an automobile repair, painting and body shop use of the existing building found at this location. The premises was most recently occupied by a vehicle sales, rental and service use that was permitted at this location. No additional information was provided by the applicant.

The property immediately west of the subject location is zoned B and currently occupied by an automobile repair, painting and body shop use. The property to the east is vacant and was most recently occupied by a vehicle sales, rental, and service use. The property to the south is zoned I-1 Light Industrial and is occupied by a vehicle sales, rental and service use. The property to the north is undeveloped, is currently used for crop production and is zoned I-2 Heavy Industrial.

COMPREHENSIVE PLAN

The goals, principles, objectives and strategies described in the Comprehensive Plan are supportive of permitting property uses that contribute positively to the neighborhood concerned and the community in general. The Plan recognizes the significant impact the built environment has on the aesthetics of the community and the overall community image.

CONCLUSION

The proposed automobile repair, painting and body shop special use of this premise will be consistent and compatible with the land use types surrounding this property. However, it should be noted that the existing improvements found at this location include a number of

STAFF REPORT

Date: February 24, 2010

Subject: 8620 N CR-25A Automobile Repair, Painting and Body Shop Special Use

Page 2

nonstandard conditions. These conditions primarily relate to the parking lot and vehicle storage areas and the deficient setbacks, screening, landscaping, and boundary control provisions provided with regards to these improvements.

RECOMMENDATION

Staff recommends that the Planning Commission **approve** this request with the following conditions:

Upon submittal of an application for a zoning permit the plans provided shall include:

- *A designated vehicle storage area for those vehicles impounded or waiting to be serviced or repaired, said storage area to be to the rear of the lot and not visible from the public right of way.*
- *A 6 foot high security fence around the entire perimeter of the vehicle storage area, with screening slats in the fence to obscure the storage area from view from adjacent properties or public spaces.*
- *Excavation of existing parking lot surface area improvements to achieve conformance with the setbacks required for such improvements; and, the inclusion of plantings in the excavated areas to satisfy the landscaping requirements of the parking regulations.*
- *Installation of boundary control features at the perimeter of the parking lot areas.*

VICINITY MAP



CITY OF PIQUA, OHIO

Application for Special Use Permit

- 1. Applicant's Name Robert Brown Phone 937-570-6705
Applicant's Address 919 Washington Ave
- 2. Owner's Name Rick James Phone 937-689-1010
Owner's Address 502 Timberlea Trails, Kettering, OH 45429
- 3. Type of legal interest held by applicant _____
- 4. Location of Special Use Permit request
A. Legal description (Inlot No. or attach legal description) 8659 N. Co. Rd.
B. Address 25-A PIQUA OHIO 45356
- 5. Existing zoning -B
- 6. Existing usage Car Sales - Service - Body Shop
- 7. Proposed usage Body and Paint Shop
- 8. Proposed special usage Body and Paint Shop
- 9. No. of plot plans submitted (10 required UNLESS waived) SAME
- 10. Describe the reason for the requested special use:
for Body Shop

I hereby certify that the proposed request is authorized by the "Owner of Record" and agree to conform to all applicable laws of the City of Piqua, Ohio.

Signature of Applicant Robert Brown Date 2-8-10

Signature of Owner [Signature] SR. Date 2-17-10

Note: Both the owner and the applicant shall sign when application is made by someone other than the owner.

***** OFFICE USE ONLY *****

\$100.00 Fee Paid 100.00 Date Fee Paid 2-18-10

Receipt No. 186388 P.C. Res. No. _____

RECEIVED

FEB 18 2010

CITY OF PIQUA
DEVELOPMENT OFFICE

ZONING MAP



Zoning		R3-Multi-Family Residential
		R2-Two-Family Residential
		R1AA-One-Family Residential
		R1A-One-Family Residential
		R1-One-Family Residential
		OS-Open Space
		I2-Heavy Industrial
		I1-Light Industrial
		F-Floodplain
		CBD-Central Business District
		B - Business
		Buffer layer
Parcels		Parcels (auto-on)
Transportation	Abc	StreetNames
		Railroad
		Highway Symbols

RESOLUTION No. PC 09-10

WHEREAS, Scott Thobe has submitted a request to change the zoning designation of parcel N44-004010 change from B General Business to R-2 Two-Family Residential, said parcel also known as 316 N. Downing Street; and,

WHEREAS, sections 154.141 of the City of Piqua Code of Ordinances provides the procedure for considering zoning designation change; and,

WHEREAS, the Planning Commission has studied the request, included herein, and conducted a public hearing on the matter;

NOW THEREFORE BE IT RESOLVED, board member _____ hereby moves to _____ the request made, as described by this resolution, the testimony provided, and the documents attached hereto, the motion is seconded by board member _____, and the voting record on this motion is hereby recorded as follows.

	AYE	NAY	ABSTAIN	ABSENT
Mr. Jim Oda	<input type="checkbox"/>	<input type="checkbox"/>	<input type="checkbox"/>	<input type="checkbox"/>
Mr. Brad Bulp	<input type="checkbox"/>	<input type="checkbox"/>	<input type="checkbox"/>	<input type="checkbox"/>
Mr. Mike Taylor	<input type="checkbox"/>	<input type="checkbox"/>	<input type="checkbox"/>	<input type="checkbox"/>
Mrs. Jean Franz	<input type="checkbox"/>	<input type="checkbox"/>	<input type="checkbox"/>	<input type="checkbox"/>
Mr. Mark Spoltman	<input type="checkbox"/>	<input type="checkbox"/>	<input type="checkbox"/>	<input type="checkbox"/>

RESOLUTION No. PC 10-10

WHEREAS, the city of Piqua, with the consent of the owner of the subject property, has submitted a request to change the zoning designation of parcel N44-004000 change from B General Business to R-2 Two-Family Residential, said parcel also known as 320 N. Downing Street; and,

WHEREAS, sections 154.141 of the City of Piqua Code of Ordinances provides the procedure for considering zoning designation change; and,

WHEREAS, the Planning Commission has studied the request, included herein, and conducted a public hearing on the matter;

NOW THEREFORE BE IT RESOLVED, board member _____ hereby moves to _____ the request made, as described by this resolution, the testimony provided, and the documents attached hereto, the motion is seconded by board member _____, and the voting record on this motion is hereby recorded as follows.

	AYE	NAY	ABSTAIN	ABSENT
Mr. Jim Oda	<input type="checkbox"/>	<input type="checkbox"/>	<input type="checkbox"/>	<input type="checkbox"/>
Mr. Brad Bubp	<input type="checkbox"/>	<input type="checkbox"/>	<input type="checkbox"/>	<input type="checkbox"/>
Mr. Mike Taylor	<input type="checkbox"/>	<input type="checkbox"/>	<input type="checkbox"/>	<input type="checkbox"/>
Mrs. Jean Franz	<input type="checkbox"/>	<input type="checkbox"/>	<input type="checkbox"/>	<input type="checkbox"/>
Mr. Mark Spoltman	<input type="checkbox"/>	<input type="checkbox"/>	<input type="checkbox"/>	<input type="checkbox"/>

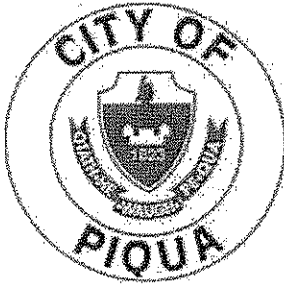

PLANNING AND ZONING

Christopher W. Schmiesing – City Planner
201 West Water Street • Piqua, Ohio 45356
(937) 778-2049 • FAX (937) 778-0809
E-Mail: cschmiesing@piquaoh.org

STAFF REPORT

Date: February 24, 2010
To: Planning Commission Members
From: Chris Schmiesing, City Planner
Subject: 316 N Downing Street and 320 N Downing Street Zoning Change

GENERAL INFORMATION

Applicant: Scott Thobe
Owner: Scott Thobe; Kevin Pryfogle
Location: 316 N Downing Street and 320 N Downing Street
Zoning: Existing – B General Business; Proposed – R-2 Two-Family Residential
Land Use
Existing: Two-family dwelling unit (both locations)
Proposed: Two-family dwelling unit (both locations)
Request: Recommendation of zoning change from B General Business to R-2 Two-Family Residential.

DISCUSSION/FINDINGS

This request is to seek a change in the zoning designation of the subject parcels. The applicant for the 316 N Downing Street is the owner of that property and initiated the request based upon his desire to have the zoning accurately reflect the current use of the premises, a two family-dwelling unit. Upon reviewing the application it became apparent to staff that the adjacent property, known as 320 N Downing Street, also was being used as a two-family dwelling unit, and that an R-2 zoning designation would also more accurately reflect the use of this premise.

A review of the zoning map records indicated that the parcels were previously zoned R-2 at the time 1971 zoning map was adopted. A subsequent zoning code update in 1982 and the map amendments adopted at that time resulted in the properties being included in a business zoning designation. Whether or not this change was intentional or in error is unknown. The same business zoning designation was continued when the zoning code and the accompanying was last updated in 1996.

COMPREHENSIVE PLAN

The Comprehensive Plan recognizes the unique qualities and characteristics of established neighborhoods such as this one and promotes the concept of utilizing zoning as a way to preserve and protect the permissibility of those uses traditionally accepted.

CONCLUSION

STAFF REPORT

Date: February 24, 2010

Subject: 316 N Downing Street and 320 N Downing Street Zoning
Change

Page 2

The proposed zoning of the subject parcels would be consistent and compatible with the surrounding land uses and zoning designations and be appropriate for the use types found at the subject premises.

RECOMMENDATION

- Staff recommends that the Planning Commission recommend the zoning change be **approved** for both of the subject parcels.

VICINITY MAP

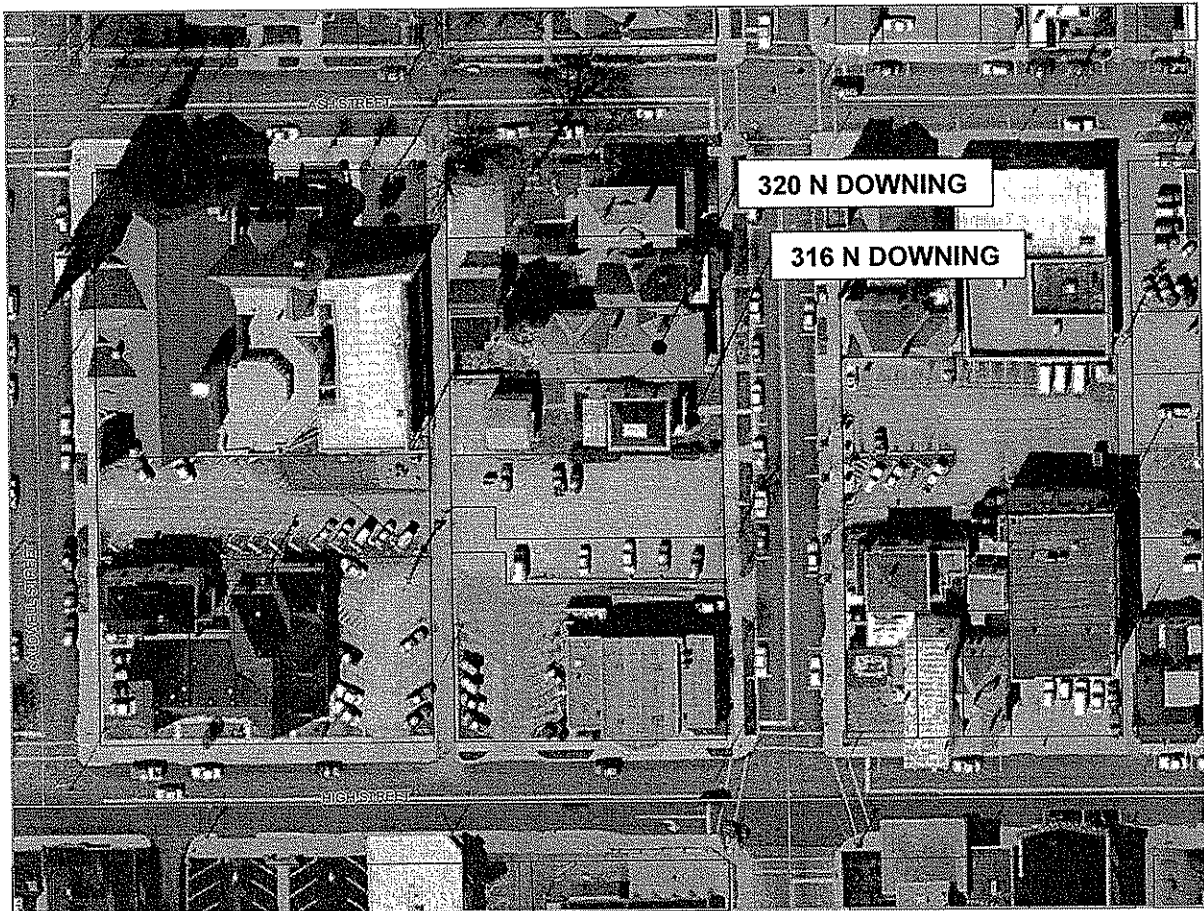

CITY OF PIQUA, OHIO

Application for Zoning Change

1. Applicant's Name Scott Thobe Phone 937-335-7851

Applicant's Address 621 Sedgwick Way Troy, OH 45373

2. Owner's Name Scott Thobe Phone 937-524-9019

Owner's Address 621 Sedgwick Way Troy, OH 45373

3. Type of legal interest held by applicant N/A (owner)

4. Location of Rezoning request

A. Legal description (Inlot No. or attach legal description) _____

B. Address 316 North Downing Piqua, OH

5. Existing zoning general business

6. Existing usage multi-family living apartments

7. Proposed zoning multi-family living apartments

8. Proposed usage multi-family living apartments

9. Is this "Request for Zoning" contingent upon annexation? Y ___ N

10. Describe the reason for the requested rezoning: Previous owner used 2nd floor as family residence & 1st floor as attorney office. Now 1st & 2nd floor are both used for family residence

11. Has a Rezoning Request for this location been made before? Y ___ N Not known
If yes, give date of previous application _____

12. No. of site plans submitted (16 required UNLESS waived) 1

I hereby certify that the proposed request is authorized by the "Owner of Record" and agree to conform to all applicable laws of the City of Piqua, Ohio.

Signature of Applicant Scott Thobe Date 2/8/10

Signature of Owner Scott Thobe Date 2/8/10

Note: Both the owner and the applicant shall sign when application is made by someone other than the owner.

***** OFFICE USE ONLY *****

~~100.00~~ Fee paid 100.00 Date fee paid 2-10-10

Receipt no. 186386 P.C. Res. no. _____

RECEIVED

CITY OF PIQUA DEVELOPMENT OFFICE

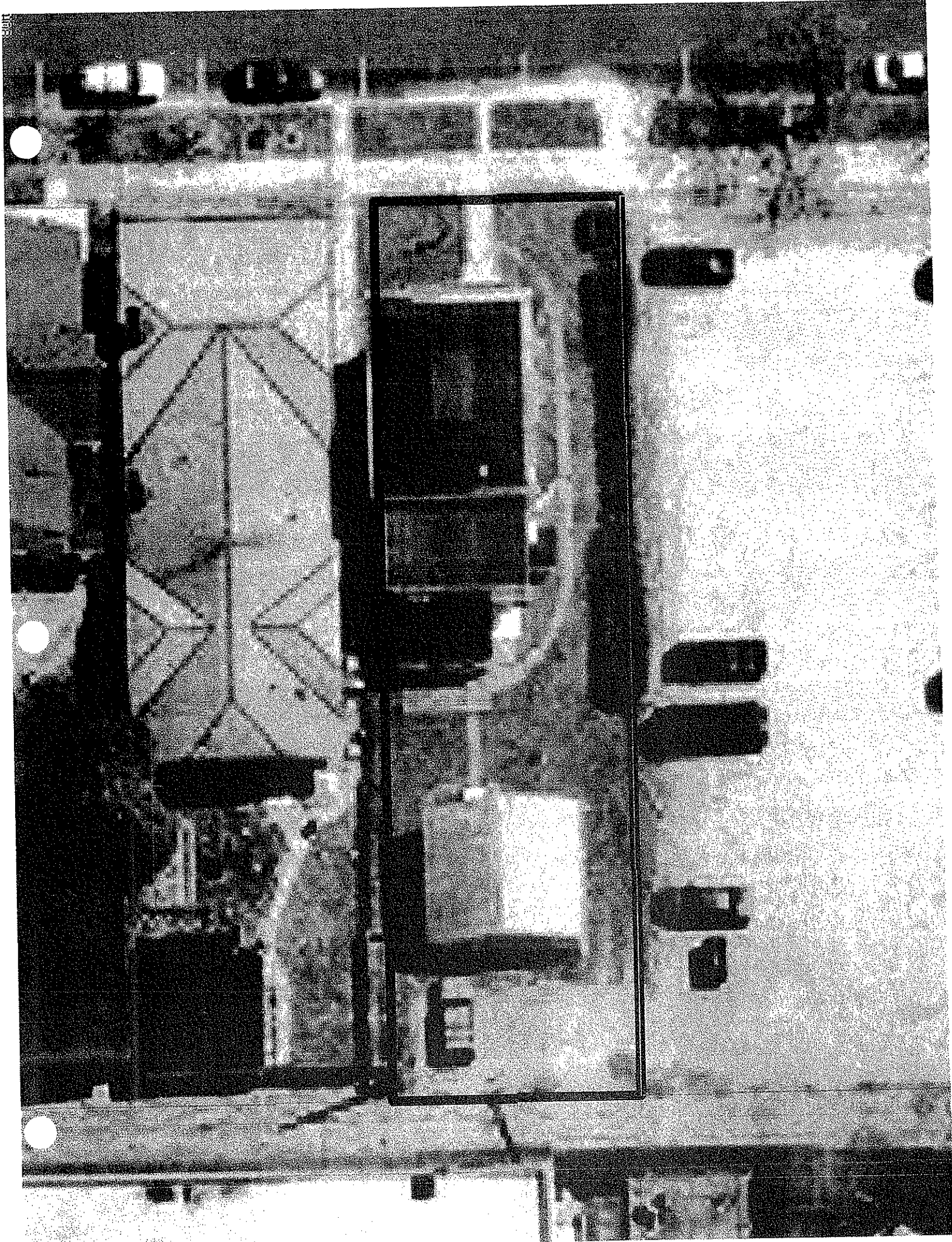

ZONING MAP

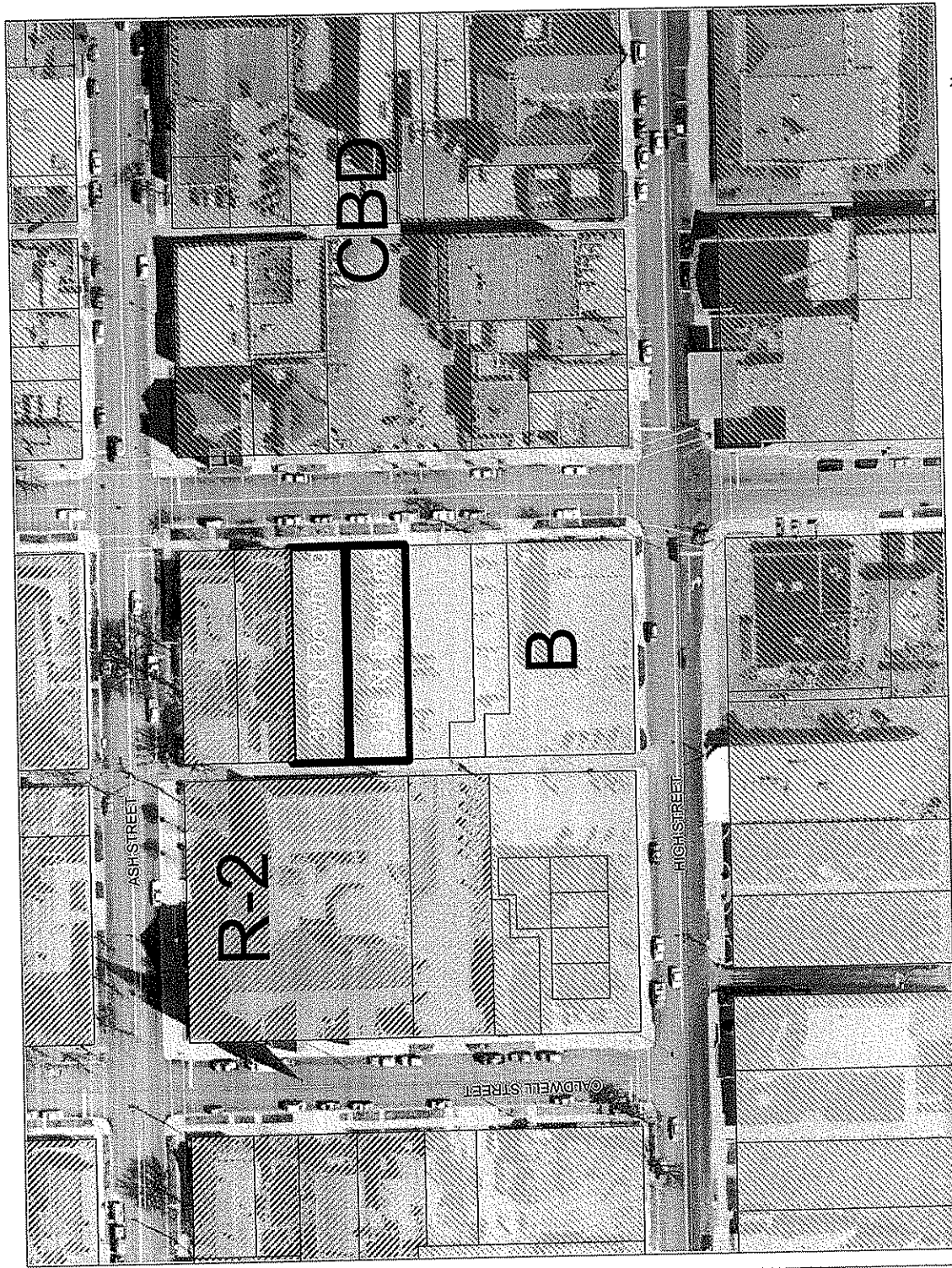

Zoning	R3-Multi-Family Residential
	R2-Two-Family Residential
	R1AA-One-Family Residential
	R1A-One-Family Residential
	R1-One-Family Residential
	OS-Open Space
	I2-Heavy Industrial
	I1-Light Industrial
	F-Floodplain
	CBD-Central Business District
	B - Business
Buffer layer	
Parcels	Parcels (auto-on)
Transportation	
	Abc StreetNames
	Railroad
	Street Centerlines
	Major Highways
Natural Features	
	Water Bodies
	Redline

RESOLUTION No. PC 11-10

WHEREAS, the Bethany Center, the owner of the subject property, has submitted a request to change the zoning designation of parcel N44-250382 change from R-1 One-Family residential to R-3 Three-Family Residential, said parcel also known as 339 South Street; and,

WHEREAS, sections 154.141 of the City of Piqua Code of Ordinances provides the procedure for considering zoning designation change; and,

WHEREAS, the Planning Commission has studied the request, included herein, and conducted a public hearing on the matter;

NOW THEREFORE BE IT RESOLVED, board member _____ hereby moves to _____ the request made, as described by this resolution, the testimony provided, and the documents attached hereto, the motion is seconded by board member _____, and the voting record on this motion is hereby recorded as follows.

	AYE	NAY	ABSTAIN	ABSENT
Mr. Jim Oda	<input type="checkbox"/>	<input type="checkbox"/>	<input type="checkbox"/>	<input type="checkbox"/>
Mr. Brad Bulp	<input type="checkbox"/>	<input type="checkbox"/>	<input type="checkbox"/>	<input type="checkbox"/>
Mr. Mike Taylor	<input type="checkbox"/>	<input type="checkbox"/>	<input type="checkbox"/>	<input type="checkbox"/>
Mrs. Jean Franz	<input type="checkbox"/>	<input type="checkbox"/>	<input type="checkbox"/>	<input type="checkbox"/>
Mr. Mark Spoltman	<input type="checkbox"/>	<input type="checkbox"/>	<input type="checkbox"/>	<input type="checkbox"/>

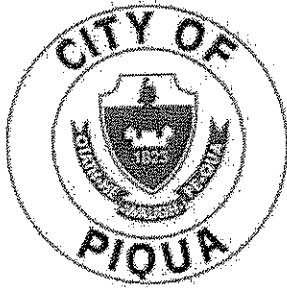

PLANNING AND ZONING

Christopher W. Schmiesing – City Planner
201 West Water Street • Piqua, Ohio 45356
(937) 778-2049 • FAX (937) 778-0809
E-Mail: cschmiesing@piquaoh.org

STAFF REPORT

Date: February 24, 2010
To: Planning Commission Members
From: Chris Schmiesing, City Planner
Subject: 339 South Street Zoning Change

GENERAL INFORMATION

Applicant: Bethany Center
Owner: Bethany Center
Location: 339 South Street
Zoning: Existing – R-1 One-Family Residential; Proposed – R-3 Multi-Family Residential

Land Use

Existing: Food pantry, clothing shop, soup kitchen
Proposed: Food pantry, clothing shop, soup kitchen, and temporary housing for people in need.

Request: Recommendation of zoning change from R-1 One-Family Residential to R-3 Multi-Family Residential

***NOTE** - This request pertains to a change in the zoning designation of the subject parcel and will not authorize the proposed "temporary housing for people in need" use. Issues and concerns related to the conformance status of a specific use/improvement with regards to applicable building and zoning standards will be addressed by special use, building permit, and zoning permit processes. To satisfy the special use, building permit, and zoning permit review processes, detailed construction documents verifying code compliance with the applicable standards must be submitted by the applicant. Upon approval of any special use of the property by the Planning Commission and after reviewing and finding that the documents conform to the applicable standards the enforcing official may approve and issue building and zoning permits for the subject use/improvements. The special use, building permit, and zoning permit processes can only occur after the subject property is properly zoned to "permit" the proposed use.*

BACKGROUND

This request is to seek a change in the zoning designation of the subject parcel. The applicant for the request is the owner of the property and has initiated the request based upon their desire to seek approval of a "temporary housing for people in need" use for this location. A review of the zoning code determined that the proposed "temporary housing for people in need" use is not listed in any of the districts included in the zoning code. When this occurs the provision in the zoning code granting the Planning commission the authority "...to consider as a special use those uses not listed as a permitted principal or special use in this chapter" must be utilized. Recognizing that the proposed use is most similar to

STAFF REPORT

Date: February 24, 2010
Subject: 339 South Street Zoning Change

Page 2

certain uses listed in the R-3 zoning district (such as boarding or lodging houses, or group homes) we must first consider whether a change to the zoning designation of the property from R-1 to R-3 (the zoning designation with "similar" uses listed) is appropriate.

The improvements found at the subject parcel were formerly occupied by an elementary school use prior to being occupied by the current use in the late 90's. The subject parcel is located in a traditional neighborhood established in the early 1900's. To the north, south, east, and west one, two and three-family dwelling units surround the subject parcel. To the northwest, diagonally across the intersection of South Street and Roosevelt Avenue, there is an elderly housing facility known as the Roosevelt Manor Apartments. Within several blocks of the subject parcel there are a host of neighborhood establishments, including but not limited to retail sales and service businesses, contractor and auto repair shops, eatery and drinking establishments, churches, an intermediate school, and a grocery.

The zoning code list as principal permitted uses within the proposed R-3 zoning designation; single-family detached and attached dwellings, two-family and multi-family dwellings, bed and breakfast inns, boarding and lodging houses, dormitories, convents and monasteries, schools, churches, libraries, recreation facilities and private clubs, and home occupations. Those uses that may be permitted in an R-3 zoning district as a special use include; elderly housing facilities, mobile home courts, group homes, child day care centers, nursing and convalescent homes, cemeteries, public office buildings, hospitals, membership sports and recreation clubs, neighborhood businesses, restaurants, and business and professional offices.

Prior to submitting this request a representative for the applicant contacted this office to determine what information should be provided with the application. Staff explained the submittal requirements and the review process and recommended that the Chief of Police and a professional architect also be consulted as part of the plan development process. Staff also suggested that the facility organizers engage the neighborhood residents in the plan development conversation. Ultimately the Chief of Police ended up in the role of city liaison concerning all matters related to the proposed use and helped to establish an initial meeting between the Bethany Center and the Southview Neighborhood Association.

COMPREHENSIVE PLAN

The Comprehensive Plan recognizes the unique qualities and characteristics of established neighborhoods such as this one and promotes the concept of utilizing zoning as a way to preserve and protect the established character of the neighborhood.

DISCUSSION

The Southview Neighborhood Association has worked diligently to improve the conditions that exist in the subject neighborhood and promote a positive image to the community. The group has placed a high level of importance on reducing the number of multi-family dwelling units and improving property values within the neighborhood. If the proposed zoning change is authorized the proposed zoning will open the door for any of the principal permitted uses listed in the R-3 zoning district to be established at this location. While the "temporary housing for people in need" use will still be subject to the special use process, a multi-family housing or boarding or lodging house use will be permissible as a principal permitted use in the proposed zoning district.

STAFF REPORT

Date: February 24, 2010
Subject: 339 South Street Zoning Change

Page 3

It difficult to measure the demand for the proposed "temporary housing for people in need"; and, it is equally difficult to measure the impact such a facility may or may not have on a neighborhood. The impact "temporary housing for people in need" uses have produced in other communities is outlined in the Homeless Shelters: A Police Perspective of Experiences in Other Cities, June 2009 report included in this packet.

The use that is being proposed if the property is successfully rezoned will introduce an additional number of persons coming and going from this location and there will be a modest increase the traffic volume in this area. Also, the use proposed will introduce 24-hour occupancy of the subject facility that currently does not exist. The plans provided with regards to the use proposed show sleeping facilities for up to 38 persons. If each person arrives separately driving his/her own automobile and the facility were operating at 100 percent of the capacity, there would be 38 vehicles parked in the parking facilities available on the lot or in the on-street parking spaces near this location. Presumably those persons arriving by foot will be permitted to congregate at the entrance to the building until the doors are opened. The facts provided herein and the information provided in the Homeless Shelters: A Police Perspective of Experiences in Other Cities, June 2009 report included in this packet suggest that the characteristics of this location and surrounding neighborhood, to some degree, will be affected by the proposed use. However, the same could be said for most any change of use or any other new use that could conceivably be introduced to this location.

Whether or not the change in the zoning designation will allow for use types of an intensity that a will be detrimental to the neighborhood is of primary concern in this matter. The stated intent of the of the R-1 zoning district "...is to provide a stable residential area for one-family housing in those parts of the city that are largely developed at a gross density of approximately seven dwelling units per acre." The stated intent of the R-3 zoning district "...is to provide a full range of residential dwelling types. The maximum approximate gross density of this district is 29 dwelling units per acre. The requirements allow a more complete use of the land in the district and provide more flexible guidelines for development and redevelopment efforts." Within the R-3 zoning district 12 principal permitted use types and 14 special use types may be permitted. Within the existing R-1 zoning designation 5 principal permitted use types and 10 special use types may be permitted. More specifically, the R-3 zoning district allows for a far greater range of residential uses, institutional uses, and retail commercial and service use types.

RECOMMEDATION

With reference to the anticipated public input and professional opinions likely to be offered concerning this request, staff chooses to defer on providing a recommendation on this item.

STAFF REPORT

Date: February 24, 2010
Subject: 339 South Street Zoning Change

Page 4

VICINITY MAP

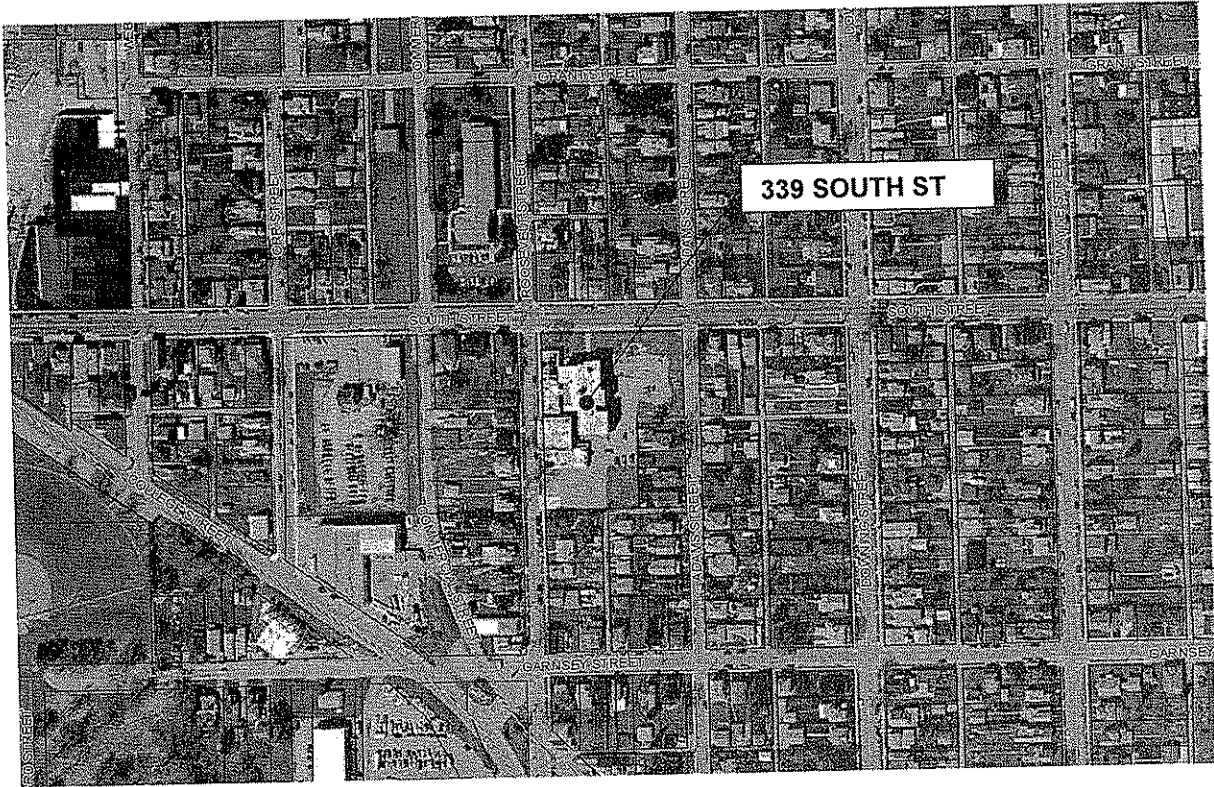

CITY OF PIQUA, OHIO

Application for Zoning Change

1. Applicant's Name Bethany Center Phone 615-9762

Applicant's Address 339 South Street, Piqua, OH 45356

2. Owner's Name Bethany Center Phone 615-9762

Owner's Address 339 South Street, Piqua, OH 45356

3. Type of legal interest held by applicant fee simple

4. Location of Rezoning request

A. Legal description (Inlot No. or attach legal description) Part Outlot 54

B. Address 339 South Street, Piqua, OH 45356

5. Existing zoning R-1-A

6. Existing usage Food Pantry, clothing shop, soup kitchen

7. Proposed zoning R-3

8. Proposed usage Temporary housing for people in need "Bethany House of Providence"

9. Is this "Request for Zoning" contingent upon annexation? Y N X

10. Describe the reason for the requested rezoning: Applicant wishes to establish a place for temporary overnight stays for local individuals in need.

11. Has a Rezoning Request for this location been made before? Y X N

If yes, give date of previous application 2005 - (withdrawn)

12. No. of site plans submitted (16 required UNLESS waived) 16

I hereby certify that the proposed request is authorized by the "Owner of Record" and agree to conform to all applicable laws of the City of Piqua, Ohio.

Signature of Applicant Bethany Center Wilma A. Earls, Director Date 1-29-10

Signature of Owner Bethany Center Catherine A. Lodge, President Date 1-29-10

Note: Both the owner and the applicant shall sign when application is made by someone other than the owner.

***** OFFICE USE ONLY *****

100.00 \$50.00 Fee paid 100.00 Date fee paid 1-29-10

Receipt no. 186381 P.C. Res. no.

Bethany House of Providence

Policies and Procedures

Mission Statement:

To provide safe, emergency housing with an open heart, helping hand to the community for no more than 30 days for persons who are in need of a place to sleep that meet the admission criteria.

Admission Criteria:

Guests must meet at least one of the following criteria:

1. Must have a mailing address within the school district of Piqua, Ohio or
2. Children enrolled within the school district of Piqua, Ohio or
3. Have immediate family (spouse, parents, children) currently living within the school district of Piqua, Ohio or
4. Be employed within the school district of Piqua, Ohio.

Registration Time

7-8 pm Registration

8-9 pm Clothing distribution/showers

9-10 pm Recreational time – guests may read, watch TV or play cards in the lounge until lights out

10 pm LIGHTS OUT

Emergency admission through the police department only.

December 29, 2009

Identification

All guests will be asked to produce photo I.D. ALL guests will be checked in and any illegal material will be given to the authorities. All guests will be asked to sign a disclaimer form.

Baggage

All baggage (this includes: boxes, bags, backpacks, hats, coats, any electrical items, such as cell phones, tobacco products, etc.) will be checked at the front desk. NO LONG TERM STORAGE OF PERSONAL ITEMS IS PROVIDED. All personal items must be picked up at the front desk upon departure. ANY PERSONAL ITEMS LEFT IN OR AROUND THE BUILDING AFTER 11 AM WILL BE DISCARDED.

Valuables

We request that all valuables (i.e. wallets, money, I.D., prescriptions or medicine not needed during the evening) be checked at the front desk and locked in the closet. During this time, shoes will be checked also. THE BETHANY CENTER /BETHANY HOUSE OF PROVIDENCE ASSUMES NO RESPONSIBILITY FOR PERSONAL ITEMS LOST OR STOLEN WHILE YOU ARE AT THE CENTER.

Wake-up/Meals

Wake-up time is 6:00 a.m. Breakfast will be served at 6:30 a.m. for the guests of the Bethany House of Providence. All food and drinks must remain in the dining room. No food or drink may be brought in from the outside.

Hot meals are available Monday through Thursday from 12 noon to 1 p.m. and on Friday between 5-6 p.m.

Departure

All guests of the Bethany House of Providence must be out of the building by 7:00 a.m. Guests may depart later under severe weather conditions or at the discretion of the Guest Attendant on duty.

December 29, 2009

The following situations may be cause to be removed from the Center/Bethany House of Providence:

- Any type of physical aggression, threats or gestures
- NO POSSESSION OF GUNS PERMITTED ON THE PROPERTY. WEAPONS FOUND ON THE PROPERTY WILL BE CONFISCATED. THOSE IN POSSESSION OF A WEAPON WILL BE EJECTED FROM THE CENTER AND THE POLICE WILL BE NOTIFIED. All other potential weapons (scissors, nail file, knives, etc.) will be checked in at the front desk
- Theft of property from guests, staff and Bethany Center/Bethany House of Providence
- NO SMOKING INSIDE THE BUILDING
- Intentional destruction or misuse of another guest's property
- Allow unapproved individuals to enter the Center/Bethany House of Providence
- Entering the opposite sex sleeping or family areas
- NO ALCOHOL OR ILLEGAL DRUGS ARE PERMITTED IN OR AROUND THE CENTER/BETHANY HOUSE OF PROVIDENCE. INDIVIDUALS IN POSSESSION OF THESE SUBSTANCES AND PARAPHANALIA WILL BE EJECTED FROM THE CENTER/BETHANY HOUSE OF PROVIDENCE AND THE POLICE WILL BE NOTIFIED. Guests are required to comply with a request to submit to a Breathalyzer test. Refusal will result in discharge. Intoxicated individuals will be refused admission to the Center.
- FIGHTING WILL RESULT IN ALL INVOLVED PARTIES BEING EJECTED FROM THE BETHANY CENTER/BETHANY HOUSE OF PROVIDENCE AND THE POLICE WILL BE NOTIFIED. If another guest is bothering you, see a staff member to resolve the situation. Peaceful behavior is necessary at all times in and around the Center/Bethany House of Providence.

December 29, 2009

Rules for Sleeping and Family Areas:

1. Guests are not permitted to use washer and dryer in the Center/Bethany House of Providence.
2. No guest is permitted to pack lunches in the evening using food from dinner or anything else. There are NO exceptions. If there is something available for lunches, it is at the discretion of the morning attendant to provide it for you.
3. All toiletries will be given out only in the evening. It is your responsibility to get what you need before you go to bed.
4. You are required to take a shower in the evening before lights go out.
5. The Bethany Center/Bethany House of Providence is not responsible for anything that you leave behind during the day.
6. You must make your bed before leaving in the morning. Guests not returning must put their sheets in the hamper in the hallway.
7. If you need clothing, you are welcome to come to the clothing bank on Tuesday between 10:00 a.m. and 12 noon or Friday between 4 – 7 p.m. The Guest Attendant on duty will give out clothing when there is an emergency.
8. Guests must be fully clothed at all times.
9. Guests may not use the phone.
10. You are not allowed to bring bags or bottles of medication in with you. You must carry all your belongings in your hands. Bring only the medication you need for the night, clothes for the next day and important toiletries.
11. You may read, watch TV, play cards and socialize in the common room until lights are out.
12. After lights are out, no talking is permitted in the sleeping areas.
13. No animals will be allowed in the Center/Bethany House of Providence (unless it's a service animal.)
14. Any parent or caretaker that does not care for or keep children under control will be asked to leave.
15. Only women with children will sleep in the Family area.
16. All men must sleep in the Men's area.
17. All women without children must sleep in the Women's area.

December 29, 2009



PIQUA POLICE DEPARTMENT

Chief Bruce A. Jamison, CLEE

100 North Wayne Street • Piqua, Ohio 45356

Phone: (937) 778-2027 • Fax: (937) 778-2008

Emergency Police Dispatch: 9-1-1 • Non-emergency: (937) 440-9911

www.piquaohpd.org • E-Mail: bjamison@piquaoh.org

HOMELESS SHELTERS: A POLICE PERSPECTIVE OF EXPERIENCES IN OTHER CITIES June, 2009

I would like to begin this report with an acknowledgement of my own opinion and perspective on this issue. I hope all will find that the remainder of the report is non-judgmental and based on facts.

The question of whether homelessness is a “problem” in Piqua requires a subjective answer based on one’s definition of a problem. However, the question of whether there is any homelessness in Piqua is definitely answered, “yes.”

The police department does not track homelessness issues separate from other services provided to the citizens. However, we routinely deal with a wide variety of people who are homeless. Sometimes we facilitate connecting the citizens with the Salvation Army for placement into a hotel room for one night. Other times we deal with shelters designed for the homeless in Troy, Miami County, and Sidney. Many of the homeless with whom we deal are mentally ill; with nowhere to go since the mental health system has been deinstitutionalized. In fact, we have been among the leaders in Ohio in collaboration to form Crisis Intervention Teams and specially trained officers to deal with this issue.

I preface this report with this information in order to acknowledge two opinions I have developed as Chief of Police:

- Homelessness exists in Piqua; and,
- Homeless shelters are one means, but should be part of a comprehensive system, to deal with the issue of homelessness.

Upon hearing of a renewed interest in establishing a homeless shelter in Piqua, I have completed some research of problems and solutions related to shelters. I was also fortunate to be invited to a meeting between the Bethany Center Homeless Shelter Committee and the Executive Board of the Southview Neighborhood Association on June 2, 2009. This group was interested in the results of my research thus far, so this report is designed to share the information to which I referred during the meeting.

ENCAMPMENTS

Some cities have experienced problems related to encampments in public or abandoned areas near shelters established for the homeless. Piqua has not experienced outdoor encampments, but some present at the June 2 meeting are familiar with a recent case of a man moving into someone’s porch. We also know of properties becoming occupied by “squatters” after they were condemned. I have found several approaches for this problem:

- Public “camping” ordinances prohibiting sleeping on sidewalks or other public rights of way.

- Aggressive education and code enforcement directed towards private property owners that permit or ignore urban camping.
- Rapid response municipal and county programs that allow public entities to assist private property owners in removal of property left on their property by trespassers.

AGGRESSIVE PANHANDLING

Troy PD has expressed seeing an increase in panhandling since the establishment of some new shelters. They recently dealt with an individual who is not homeless, but has chosen to make his living this way. A city employee recently went to a store in a nearby city and was approached by someone as she walked to her car that was so aggressive the means probably could constitute a robbery, had she reported it. Potential solutions:

- Ordinances defining and prohibiting specific conducts that are frequently a part of "aggressive panhandling."
- Public education by both law enforcement and homeless advocates discouraging people from giving directly to the panhandlers and encouraging financial support of established homeless programs

COMMUNITY INVOLVEMENT

Several police departments reported shelters being established and creating multiple issues in the communities where they were placed. As a solution to these issues, police and neighborhood involvement were established with the shelter after-the-fact. We are fortunate to have already opened that dialog.

- Police were given a seat on the board of directors in one city.
- One shelter has a "Neighborhood Advisory Panel"

RESTRICTING ASSISTANCE TO LOCAL CITIZENS IN NEED

I have challenged the committee to decide on a target population to be served by a shelter. It seems that there is interest in keeping it available for assistance to our own local citizens only, but there are also some interested in serving transient populations. I was impressed with the criteria used by a homeless shelter in St. Charles, IL, who limits admission to applicants who meet one of the following criteria:

- Have a mailing address within the school district of St. Charles, Geneva, Batavia, or Kaneland in the last two (2) years.
- Currently employed within the St. Charles, Geneva, Batavia, or Kaneland school district.
- Children who are enrolled in the St. Charles, Geneva, Batavia, or Kaneland school district.
- Have immediate family (spouse, parents, children) currently living within the St. Charles, Geneva, Batavia, or Kaneland school district.

POLICE DEPARTMENT POLICIES

Police departments that are actively involved in assisting the homeless need to know they have the support of the community if they are going to act in this role and need to adjust policies in order to protect the department and their officers from litigation. If homeless advocacy groups have an adversarial relationship with the police, there tends to be allegations of harassment and discrimination. Unclear policy only serves to fuel these allegations.

For the police department to provide meaningful support for establishment of a shelter in our jurisdiction, we would expect community support for the following policies:

- A definition of "homeless"

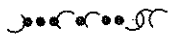

DATE	DOCUMENT NO	DESCRIPTION	FILING	EXPED	PENALTY	CERT	COPY
1. 4/14/2000	200010300211	ARN DOMESTIC ARTICLES/NON-PROFIT	25.00	10.00	0.00	0.00	0.00
TOTAL			25.00	10.00	0.00	0.00	0.00

Return To:
MCCULLOCH, FELGER, FITE & GUTMAN
ATTN P P GUTMANN
P O BOX 910
PIQUA, OH 45365-0910

cut along the dotted line



The State of Ohio
Certificate

Secretary of State - J. Kenneth Blackwell

1147416

It is hereby certified that the Secretary of State of Ohio has custody of the business records for BETHANY CENTER and that said business records show the filing and recording of:

Document(s)
DOMESTIC ARTICLES/NON-PROFIT

Document No(s):
200010300211

United States of America
State of Ohio
Office of the Secretary of State

Witness my hand and the seal of the Secretary
of State at Columbus, Ohio, This 11th day of
April, A.D. 2000



J. Kenneth Blackwell
J. Kenneth Blackwell
Secretary of State

ARTICLES OF INCORPORATION
OF
BETHANY CENTER

RECEIVED
APR. 10 2000
J. KENNETH GLASGOWELL
SECRETARY OF STATE

The undersigned, a majority of whom are citizens of the United States, desiring to form a corporation, not for profit, under Section 1702.01 et. seq., Revised Code of Ohio, do hereby certify:

FIRST: The name of said corporation shall be Bethany Center.

SECOND: The place in Ohio where the principal office of the corporation is to be located is 528 Broadway, Piqua, (Miami County) Ohio.

THIRD: The purpose or purposes for which said corporation is formed are:

(a) The corporation is organized exclusively for charitable, religious, educational, and scientific purposes, including, for such purposes, providing food, shelter, clothing and assistance to the needy and the making of distributions to organizations that qualify as exempt organizations under Section 501(c)(3) of the Internal Revenue Code, or the corresponding provision of any future United States Internal Revenue Law.

(b) In general, to do any and all acts and things, and to exercise any and all powers which it may now or hereafter be lawful for the Corporation to do or exercise under and pursuant to the laws of the State of Ohio in order to accomplish any of the purposes of the Corporation.

FOURTH: The names and addresses of the persons who are to be the initial Trustees of the corporation are as follows:

Joan Dunn, 323 Westview Drive, Piqua, Ohio 45356.
Nancy Johnston, 1770 Parker Drive, Piqua, Ohio 45356.
Arthur Good, 718 N. Wayne Street, Piqua, Ohio 45356.

FIFTH: No part of the net earnings of the corporation shall inure to the benefit of, or be distributable to its members, trustees, directors, officers, or other private persons, except that the corporation shall be authorized and empowered to pay reasonable compensation for services rendered and to make payments and distributions in furtherance of the purposes set forth in Article Third hereof. No substantial part of the activities of the Corporation shall be the carrying on of propoganda, or otherwise attempting to influence legislation, and the corporation shall not participate in, or intervene in (including the publishing or distribution of statements) any political campaign on behalf of or in opposition to any candidate for public office. Notwithstanding any other provision of these Articles, the corporation shall not carry on any other activities not permitted to be carried on (1) by a corporation exempt from federal income tax under Section 501(c)(3) of the Internal Revenue Code or the corresponding provision of any future United States Internal Revenue Law, or (2) by a corporation, contributions to which are deductible under Section 170(c)(2) of the Internal Revenue Code, or the corresponding provision of any future United States Internal Revenue Law or Federal Tax Code.

SIXTH: Upon the dissolution of the corporation, assets shall be distributed for one or more exempt purposes within the meaning of Section 501(c)(3) of the Internal Revenue Code, or the corresponding section of any future federal tax code, or shall be distributed to the federal government, or to a state or local government, for a public purpose. Any such assets not so disposed of shall be disposed of by a Court of Competent Jurisdiction of the county in which the principal office of the corporation is then located, exclusively for such purposes or to such organization or organizations, as said Court shall determine, which are organized and operated exclusively for such purposes.

IN WITNESS WHEREOF, we have hereunto subscribed our name, this 4th day of April, 2000.

BETHANY CENTER

By: Joan Dunn
Joan Dunn

By: Nancy Johnston
Nancy Johnston

By: Arthur Good
Arthur Good

ORIGINAL APPOINTMENT OF AGENT

The undersigned, being at least a majority of the incorporators of Bethany Center hereby appoint Joan Dunn, a natural person resident of Ohio in which the corporation has its principal office upon whom any process, notice or demand required or permitted by statute to be served upon the corporation may be served. Her complete address is: 323 Westview Drive, Piqua, Miami County, Ohio 45356.

BETHANY CENTER

By: Joan Dunn
Joan Dunn

By: Nancy Johnston
Nancy Johnston

By: Arthur Good
Arthur Good

Piqua, Ohio
April 4, 2000

TO: BETHANY CENTER

I hereby accept appointment as agent of your corporation upon whom process, tax notices or demands may be served.

Joan Dunn
Joan Dunn

Mission Statement

*The Bethany Center is an
ecumenical ministry in
Piqua manifesting God's
love by sharing
resources, offering
guidance and education,
and serving those in
need.*

THE BETHANY CENTER
(An Ohio nonprofit corporation, the "Corporation")

BYLAWS AND REGULATIONS

Article I
Corporate Purpose

Section 1.1. Purpose. The Corporation is organized exclusively for charitable, religious, educational, and scientific purposes within the meaning of Section 501(c)(3) of the Internal Revenue Code of 1986, as amended (the "Code") (or the corresponding provision of any future United States Internal Revenue Law) including, for such purposes, the making of distributions to organizations that qualify as exempt organizations under Section 501(c)(3) of the Code. The specific purposes for which the Corporation is organized and for which it shall be operated include the following:

(a) *Community Service Mission.* The Corporation shall assist in meeting the physical, mental and spiritual needs of the greater Piqua, Ohio community in the spirit of Jesus Christ. The Corporation subscribes to these goals, philosophy and mission of service to the community, and to minister to persons in need without regard to race, religion, gender or national origin.

(b) *Education.* The Corporation will promote and support education by conducting educational classes and through distributions to or for the benefit of exempt educational organizations and their related projects, programs and activities.

(c) *Health.* The Corporation will promote and improve the health of the general public by conducting health-related clinics and other health education classes and activities and through distributions in support of health related projects, programs and activities.

(d) *Relief of Poor and Distressed.* The Corporation will provide assistance in the relief of poor and underprivileged members of the community.

(e) *In General.* The Corporation will do such other lawful acts or activities to accomplish its charitable purposes as contemplated by Section 501(c)(3) of the Code and the nonprofit corporation laws of the State of Ohio.

Section 1.2. Corporate Autonomy. Although affiliated through common religious bonds and mission with other Churches, Denominations and Organizations, the Corporation is hereby formed as, and shall remain throughout the period of its existence, a separate and distinct corporate entity. The Corporation shall incur liability solely through and with respect to legitimate corporate acts and obligations undertaken or authorized by the Members of the Corporation, its officers or Board of Trustees ("Board") as appropriate in the particular case. The Corporation shall neither bear nor incur liability of any form or amount resulting from the acts or obligations of any person or organization other than the Corporation, except as undertaken or authorized pursuant to the preceding sentence. Conversely, no affiliate or organization of or related to these Churches, Denominations or

Organizations shall bear or incur liability of any form or amount solely as a result of their relation to the Corporation.

Article II Constituent Churches

Section 2.1. Identification. Constituent Churches are those congregations who have signed a "*Commitment to Participate*" document. These documents shall be kept on file at the Bethany Center Office. (See appendix 1: Sample document.)

Section 2.2. Admission of Additional Constituent Churches. The Board of Trustees shall approve the admission of additional churches at the meeting following receipt of a "*Commitment to Participate*" document. The names of members of the Corporation as outlined in section 3.2 shall be submitted at this meeting. The Trustee will join the Board at this meeting according to section 4.2 (a).

Article III Members

Section 3.1. Membership Qualifications. The Members of the Corporation shall be individuals who have been nominated by the Constituent Churches (as set forth in Section 2.2) and approved and appointed as Members by the Board of Trustees.

Section 3.2. Members Nominated by Constituent Organizations. Each of the following Constituent Churches shall be entitled to nominate Members of the Corporation as follows:

(a) *Constituent Churches* (Congregational Christian United Church of Christ, Madison Avenue First Church of God, Good Shepherd Presbyterian Church, Grace United Methodist Church, Piqua Baptist Church, Piqua Seventh Day Adventist Church, Piqua United Pentecostal Church, Saint Boniface Catholic Church, Saint James Episcopal Church, Saint John Evangelical Lutheran Church, Saint Mary Catholic Church, Saint Paul's United Church of Christ, Salvation Army, Union Baptist Church, collectively the "Constituent Churches"): Three (3) Members per church.

(Section 3.3. Membership Book. The Corporation shall maintain a record of membership, which shall contain the name and address of each Member of this Corporation and the date of his or her appointment to membership. Only individuals whose names are listed as Members in the membership records of the Corporation as holding voting rights on the record date (as described in Section 2.4) shall be entitled to notice of meetings and to vote on any matter properly submitted to the Members for their vote, consent, waiver, release or other action.

Section 3.4. Record Date for Meetings of the Members. The Board shall fix a time not exceeding sixty (60) days and not less than seven (7) days preceding the date of any meeting of the Members, as a record date for the determination of the Members entitled to notice of and entitled to vote at any such meeting. Only the persons who are Members of record on the date so fixed shall be entitled to notice of and to vote at such

meeting, notwithstanding any termination of membership on the books of the Corporation after any record date fixed, and such persons shall conclusively be deemed to be the Members of the Corporation on such record date notwithstanding notice or knowledge to the contrary.

Section 3.5. Annual Meeting. The annual meeting (the "annual meeting" or "constituency meeting") of the Members of the Corporation shall be held for the purpose of electing Trustees and for the consideration of reports to be presented at the meeting. The annual meeting shall be held at the Corporation's principal office located at 339 South Street, Piqua, in Miami County, Ohio or such other place in or outside the State of Ohio, as the Board or Chairperson may designate. The date of the annual meeting shall be designated by the Board.

Section 3.6. Special Meetings. Special meetings of the Members shall be held at such times and places, in or outside the State of Ohio, as may be specified in the notice therefore, whenever called by any of the following: (a) the Chairperson, or in case of the Chairperson's absence, death or disability, the Vice-Chairperson authorized to exercise the authority of the Chairperson; (b) the Secretary; (c) five Trustees acting with or without a meeting; or (d) ten Members acting with or without a meeting. Upon a request in writing delivered to the Chairperson or to the Secretary by any persons entitled to call such meeting of Members, stating the purposes for which such meeting is called, it shall be the duty of the Chairperson or the Secretary to give notice thereof to the Members in the manner set forth in Section 3.7, and if such request be refused, then the persons making such request may fix the time of the meeting, and give notice thereof in the manner set forth in Section 3.7.

Section 3.7. Notice of Meetings. Written notice of the annual and all special meetings of Members shall state the time, place and general purposes thereof and shall, unless waived by such Members, be given by the Chairperson or the Secretary to each Member entitled to notice of such meeting, by personal delivery or by mailing such notice at least seven (7) but not more than sixty (60) days before the date fixed for such meeting to each Member so entitled to notice of such meeting. Absent timely action by those officers, notice may be issued by the person(s) who called the meeting under Section 3.6. If such notice is mailed, such notice shall be addressed to the Member at his or her address as the same appears upon the records of the Corporation. Notice of adjournment of a meeting need not be given if the time and place to which it is adjourned are fixed and announced at such meeting.

Section 3.8. Waiver of Notice of Meeting. A Member may waive notice of the time, place and purpose of any meeting of Members, either: (a) by written waiver, signed and filed with or entered upon the records of the meeting, either before or after such meeting; or (b) by the attendance of such Member at such meeting, without protesting, prior to or at the commencement of such meeting, the lack of proper notice.

Section 3.9. Quorum. At any meeting of Members of the corporation, one third (1/3) of the Members present shall constitute a quorum. The majority of Members present at any meeting of Members, even if those present are less than one third (1/3), shall constitute a quorum for the limited purpose of adjourning the meeting from time to time without notice other than announcement at such meeting, until a quorum competent to act on any matter or proposal is present, and at any such subsequent meeting there may be transacted any business which might have been transacted at the meeting as originally notified.

Section 3.10. Voting. At any meeting of Members, each person who is a Member of the Corporation on the record date fixed pursuant to Section 2.4 as the record date for the determination of Members entitled to vote at such meeting, or if no such record date shall have been fixed, then at the time of such meeting, shall be entitled to one (1) vote on each matter properly submitted to the Members for their vote, consent, release or other action. At any meeting of Members at which a quorum is present, all questions coming before the Members for decision shall be decided by a vote of a majority of Members at the meeting, unless a greater proportion is required by law or by an agreement or action of the Corporation.

Section 3.11. No Proxies. At any meeting of the Members, annual or special, no Member shall be permitted to vote by proxy.

Section 3.12. Action in Writing Without Meeting. Any action which may be taken by the Members of the Corporation at a meeting may be taken without a meeting in a writing or writings if a majority of the Members who would be entitled to notice of a meeting consent in writing, unless a greater proportion is required by law, the Articles of Incorporation or these Regulations, in which case such greater proportion shall be the number of Members who must consent in writing. Any such actions in writing or writings shall be filed with or entered upon the records of the Corporation and shall be effective the date the last person signs such action or the date designated as the effective date in such writing or writings.

Section 3.13. Order of Business. At all Members' meetings, after the ascertainment of Members present, the business of the Corporation shall be considered in such order as the Chairperson or a majority of the Members deem advisable and expedient.

Section 3.14. Annual Report. The Board shall present at the annual meeting of the Members a report, verified by the Chairperson and Treasurer, or verified by a majority of the Board, showing the whole amount of real and personal property owned by the Corporation, where located and where and how invested, the amount and nature of the property acquired during the year immediately preceding the date of the report and the manner of the acquisition; the amount applied, appropriated or expended during the year immediately preceding such date, and the purposes, objects or persons to or for which such applications, appropriations or expenditures have been made; and the names and places of

residence of the persons who have been approved and appointed as Members of the Corporation during such year, which report shall be filed with the records of the Corporation and an abstract thereof entered in the minutes of the proceedings of the annual meeting.

Section 3.15. Liability of Members. Members of the Corporation shall not be personally liable to creditors of the Corporation for any indebtedness or liability of the Corporation. Any and all creditors of the Corporation shall look only to the assets of the Corporation for payment.

Section 3.16. Removal and Expiration of Term. Any Member may be removed by a two-thirds (2/3) vote of the Board upon recommendation of the Constituent Organization that nominated the Member. A Member's term shall automatically end at such time as the Member ceases to fulfill the qualifications of a Member set forth in these Regulations. A successor to the removed Member shall be nominated by the pertinent Constituent Organization.

Article IV Board of Trustees

Section 4.1. Trustees; Qualifications; Term. All of the authority of the Corporation shall be exercised, and all of the property and assets of the Corporation shall be managed and controlled, by the Board, except as otherwise provided in the Articles of Incorporation or by Chapter 1702 of the Ohio Revised Code. The Members of the Corporation shall elect the Board from nominations made under Section 3.2 at each annual meeting at which Trustees are to be elected. Each Trustee shall, prior to such nomination, become informed of, and affirm in writing support for, the values, purpose and mission of the Corporation as set forth in Section 1.1. Each person nominated to the Board shall become a Trustee upon approval by a majority of the Members. The number of Trustees shall be determined as set forth in Section 3.2 and shall not be less than three (3). The initial Trustees of the Corporation shall hold office for a term of three years and until their successors are duly elected at the annual meeting of the Corporation. At each annual meeting at which Trustees are to be elected, the successors to the Trustees shall be elected to hold office for a term of three (3) years. After the initial three years no more than one third (1/3) of the elected Trustees shall be replaced at the annual elections.

Section 4.2. Composition of the Board of Trustees.

(a) *Church Representatives.* Members representing Constituent Churches shall be entitled to nominate the following number of Trustees:

(i) Each Church: One (1) Trustee

(b) *Ex-officio Representatives.* Ex-officio trustees shall be nominated by those members of the Board from the Constituent Churches.

(ii) Their number shall not exceed one-third (1/3) of the number of trustees from the Constituent Churches.

- (iii) The Executive Director will be an ex-officio member of the Board of Trustees in addition to the ex-officio members nominated by the Constituent Churches.

Section 4.3. Paid Employees. Paid employees cannot serve as representatives of the Constituent Churches.

Section 4.4. Vacancies. The office of a Trustee shall become vacant if a Trustee dies, resigns, or ceases to qualify as a Trustee under these Regulations. A resignation shall take effect upon delivery of written notice to the Secretary of the Corporation, or at such other time as said Trustee resigning may specify. The remaining Trustees, though less than a majority of the whole authorized number of Trustees, may, by a vote of the majority of their number, fill any vacancy in the Board for the unexpired term. The Trustee elected to fill a vacancy shall serve until the expiration of the term and until his or her successor is elected and qualified. The vacancy shall be filled by a person nominated from the constituent organization that is directly affected by the vacancy.

Section 4.5. Removal. All of the Trustees or any individual Trustee may be removed from office by the vote of a majority of the Members present at a meeting of Members called for the purpose of removing Trustees. Any individual Trustee may be so removed by the Board, with or without cause, by the affirmative vote of two-thirds of the Board, respectively. Such removal shall create a vacancy on the Board. The Secretary of the Board of Trustees shall notify the Constituent Organization directly affected before the removal of the individual takes place.

Section 4.6. Compensation. Trustees shall not receive any salary or other compensation for their services as Trustees. Trustees may receive, pursuant to resolution of the Board, reimbursement of expenses incurred in the performance of their duties as trustees, including, without limitation, as members of committees of the Board.

Section 4.7. Meetings.

(a) *Regular Meetings.* The Board shall meet on a regular basis as it determines necessary to conduct the business of the Corporation. The Chairperson of the Board (in his or her discretion) may determine that any monthly meeting would be inconvenient or unnecessary, in which case the Board need not meet.

(b) *Annual Meeting.* The annual meeting of the Board shall be held immediately following the annual meeting of Members, and no notice of such meeting shall be required to be given.

(c) *Special Meetings.* Special meetings of the Board may be held from time to time, whenever called by the Chairperson or the Vice Chairperson or upon the written request delivered to the Chairperson or Secretary by five Trustees.

Section 4.8. Place of Meetings; Telephonic Meetings. All meetings of the Board shall be held at the principal office of the Corporation or at such other place in or outside of the State of Ohio, as the Chairperson or the Board may determine from time to

time and as may be specified in the notice thereof. Any meeting of the Board may be held by telephone or other communications equipment if all persons participating can hear each other and participation in a meeting pursuant to such telephone or other communications equipment shall constitute presence at the meeting.

Section 4.9. Notice. Notice of the time and place of each meeting of Trustees for which such notice is required by law, the Articles of Incorporation, or the Regulations shall be given to each of the Trustees by any of the following methods:

(a) *Mail.* In a writing mailed not less than three days before such meeting and addressed to the residence or usual place of business of a Trustee, as such address appears on the records of the Corporation; or

(b) *Telegraph, cable, facsimile, etc.* By telegraph, cable, radio, wireless, facsimile, electronic mail or a writing sent or delivered to the residence, usual place of business or electronic mail address of a Trustee as the same appears on the records of the Corporation, not later than two days before the date on which such meeting is to be held; or

(c) *Personally or telephone.* Personally or by telephone not later than the day before the date on which such meeting is to be held.

Notice given to a Trustee by any one of the methods specified in these Regulations shall be sufficient, and the method of giving notice to all Trustees need not be uniform. Notice of any meeting of Trustees may be given only by the Chairperson or the Secretary of the Corporation. No such notice need specify the purpose or purposes of the meeting. Notice of adjournment of a meeting of Trustees need not be given if the time and place to which it is adjourned are fixed and announced at such meeting.

Section 4.10. Quorum. At all meetings of the Board, 50% of the Trustees in office shall constitute a quorum, but less than a quorum present may adjourn such meeting. Except as otherwise provided by law or in the Regulations, any business may be transacted at any meeting of the Board at which a quorum is present and the act of a Majority of the Trustees present at a meeting at which a quorum is present shall constitute the act of the Board.

Section 4.11. Bylaws. For the government of its actions, the Board shall adopt these bylaws and regulations consistent with the Articles of Incorporation. These bylaws shall be reviewed, revised and amended at the annual meeting by the Members.

Section 4.12. Action in Writing Without Meeting. Any action that may be taken by the Board at a meeting may be taken without a meeting in a writing or writings, if all of the members of the Board consent in writing. All such writings shall be filed with or entered upon the records of the Corporation and shall be effective the date the last person signs such writing or the date designated as the effective date in such writing or writings.

Article V
Committees of the Board of Trustees

Section 5.1. Standing Committees. In addition to such other committees as the Board may from time to time authorize or appoint, there shall be a standing Executive Committee. The Chairperson and Vice-Chairperson shall be ex-officio voting members of all committees created by the Board, and shall be counted for quorum. Each committee shall consist of at least three (3) Trustees.

The Board from time to time may create such other committees to serve at the pleasure of the Board, with such membership, powers and duties as may be deemed necessary or advisable in conducting the business, activities and affairs of the Corporation, and shall elect the members thereof. Members of all committees must be Trustees of the Corporation. The resolution or other action of the Board creating such committees shall describe the composition, responsibilities and authority of the committee.

Section 5.2. Terms of Office and Procedures of Committees. All Committee members shall hold office from the date of their election or appointment until the next annual meeting of the Board, and until their successors are elected and qualified.

A majority of the members of each committee shall constitute a quorum, unless otherwise provided in these Regulations, and the act of a majority of the members at the meeting at which a quorum is present shall constitute the act of such committee.

Section 5.3. Executive Committee. The Board shall elect from their number an Executive Committee, which shall consist of not less than three (3) Trustees and which shall include the Chairperson, Vice Chairperson, the Secretary and the Treasurer of the Corporation. The Chairperson shall serve as Chairperson of the Executive Committee. Between meetings of the Board, the Executive Committee shall have and may exercise in the absence of specific direction from the Board, any and all powers of the Board in the management of the business and affairs of the Corporation and in the appointment and removal of Officers, agents and employees of the Corporation. The Executive Committee shall cause minutes to be kept of its meetings, which minutes shall be submitted to the Board at its next succeeding meeting.

If for any reason the Executive Committee is not elected at the annual meeting of the Board, or in the event of any vacancy therein, the members of such Executive Committee may be elected and the vacancy filled at any meeting of the Board, provided notice therefore is given in the notice of the meeting. The member to fill the vacancy may be elected upon nomination by the Executive Committee, and the vacancy filled at any time by written ballot signed by a majority of the Board and delivered by mail or otherwise to the Secretary of the Corporation, and the person who shall receive the written votes of at least a majority of the Trustees shall be elected.

Article VI
Officers

Section 6.1. General. The Officers of the Corporation shall consist of a Chairperson, a Vice-Chairperson, a Secretary, and a Treasurer. All Officers shall be chosen

from among the Trustees. The Chairperson shall serve as Chairperson of the Board. The Board may designate such other offices from time to time with duties as the Board deems appropriate.

Section 6.2. Election and Term of Office. The Officers shall be elected by the Board at its annual meeting. If for any reason such meeting is not held in any year, the Officers shall be elected at the next meeting of the Board. Vacancies may be filled or new offices created and filled at any meeting of the Board. Each Officer shall hold office until the next annual meeting of the Board and until his or her successor shall have been elected and shall have been qualified, or until his earlier death, resignation or removal.

Section 6.3. Chairperson. The Chairperson shall be the principal representative of and spokesman for the Corporation. The Chairperson shall be responsible for stimulating public understanding and support for the purposes and objectives of the Corporation. The Chairperson shall preside at all meetings of the Members and of the Board. The Chairperson shall have general charge and supervision of the business and affairs of the Corporation, and shall do and perform such other duties as may be assigned to him or her from time to time by the Board.

Section 6.4. Vice Chairperson. At the request of the Chairperson, or in the event of the Chairperson's absence or disability, the Vice-Chairperson, at any time and from time to time, may perform any and all of the duties of the Chairperson, and shall have such other duties as the Board may from time to time determine.

Section 6.5. Secretary. The Secretary shall keep minutes of all the proceedings of the Members and Board and shall make proper record of the same, give notice of meetings of Members and Trustees, keep such books, including membership books as may be required by law or the Board, and perform such other and further duties as may from time to time be assigned to him or her by the Board or by the Chairperson. All books and papers pertaining to his office shall, for any reasonable and proper purpose, be subject at any reasonable time to the inspection of any Member or Trustee, and, on the expiration of this term of office, the Secretary shall deliver all books, papers and other property of the Corporation, in his or her possession or control, to the Chairperson or to the Secretary's successor in office. In general, the Secretary shall perform all duties pertaining to such office which may be required by the Chairperson or Board.

Section 6.6. Treasurer. The Treasurer shall have general supervision of all finances of the Corporation. The Treasurer shall receive and safely keep all moneys and choses in action belonging to the Corporation and shall perform such other duties as from time to time may be assigned by the Board. The Treasurer shall keep proper books of account and keep accurate account of the finances of the Corporation, and a balance sheet containing a summary of the assets and liabilities, stated capital and surplus, as of the close of its fiscal year, at the annual meeting of Members. At any meeting of the Board, the Treasurer shall furnish abstracts of the financial condition of the Corporation as of the date requested by the Chairperson or said Board. Upon the expiration of the Treasurer's term of office, the Treasurer shall deliver all money, books, papers and other property of the Corporation, in his or her possession or control, to his or her successor in office.

Section 6.7. Removal or Delegation. Any Officer elected by the Board shall be subject to removal by the Board at any time, with or without cause. In case of the absence

of any officer of the Corporation, the Board may, without removal, delegate the powers and duties of such officer to any other officer, or suitable person selected by the Board for such period as the Board may deem proper, subject, however, to any limitations herein contained and only to the extent permitted by law.

Article VII Fiscal Year and Indemnification

Section 7.1. Fiscal Year. The fiscal year of the Corporation shall commence the first day of January of each year and end on December 31 of each year.

Section 7.2. Indemnification. Each Member, Trustee, officer, director, employee, agent or volunteer of this Corporation, and any member, trustee, officer, director, employee, agent or volunteer of any other corporation serving as such at the request of this Corporation shall be indemnified by this Corporation under the standards set by and to the fullest extent allowable under Section 1702.12(E) of the Ohio Revised Code, as the same shall be amended from time to time. The Board may elect to purchase insurance to provide coverage consistent with this indemnification as the Board considers appropriate and in the best interests of the Corporation.

Article VIII Amendments to Regulations

Upon recommendation by the Board, at any meeting of the Members of the Corporation, these Regulations may be altered, amended and restated, or repealed by a majority vote of the Members present at the meeting, provided the notice of the meeting states this issue as one of the purposes of the meeting.

Article IX Conflict of Interests Policy

Section 9.1. Purpose. The purpose of this Conflict of Interests Policy is to assist the Board in carrying out its obligation to preserve and apply the Corporation's assets exclusively in furtherance of those purposes of the Corporation as are consistent with its status as an organization exempt from federal income tax pursuant to sections 501(a) and 501(c)(3) of the Code.

Section 9.2. Definitions. For purposes of this Policy:

(a) "Compensation" includes wages paid to an employee for services rendered, payments to an independent contractor, remuneration or other consideration of any type whatsoever for any services rendered and any direct or indirect payment, remuneration, transfer of assets, whether for services or otherwise, and gifts or favors which are substantial in nature.

(b) "Conflict of Interests" shall mean any circumstance or situation which involves in any way both the interests of the Corporation, whether financial or otherwise,

and a Financial Interest of any Interested Person, including but limited to Transactions between the Corporation and Interested Persons and Transactions involving the Corporation and any entity in which an Interested Person has a Financial Interest.

(c) "Family member" shall mean any ancestor, a spouse, a brother or sister and the spouse of any brother or sister, children, grandchildren and great-grandchildren and the spouses of children, grandchildren and great-grandchildren.

(d) "Financial Interest" shall mean any

(i) receipt of Compensation from, or

(ii) ownership or investment interest in , or

(iii) potential arrangement for the receipt of Compensation from or potential ownership or investment interest in,

any corporation (including the Corporation), partnership, limited liability company, trust, business organization, sole proprietorship or other business entity (including, in the case of Compensation, the receipt of Compensation from any individual), whether received or held or to be received or to be held directly or indirectly, through business dealings, family relationships (whether through or on account of a Family Member or otherwise), investments, or otherwise.

(e) "Interested Person" shall mean:

(i) any Trustee, the Chairperson of the Corporation, the Vice-Chairperson of the Corporation, the Secretary of the Corporation, the Treasurer of the Corporation and any other officer of the Corporation or any other person having powers or responsibilities similar to those of trustees or officers of the Corporation,

(ii) any person who was, at any time during the 5-year period immediately preceding the effective date of a proposed Transaction in a position to exercise substantial influence over the affairs of the Corporation, no matter whether such person is otherwise classified as an Interested Person pursuant to any other clause of this Section 8.2(e),

(iii) a member of a committee of the Corporation which enjoys board delegated powers,

(iv) a Family Member of any individual described in clause (i), (ii) or (iii) of this Section 8.2(e), and

(v) a 35-percent Controlled Entity.

(f) A "35-percent Controlled Entity" means

(i) a corporation in which persons described in clauses (i) through (iv) of Section 8.2(e), either alone or collectively, own more than 35 percent of the total combined voting power,

(ii) a partnership in which persons described in clauses (i) through (iv) of Section 8.2(e), either alone or collectively, own more than 35% of the profits interest, and

(iii) a trust or estate in which persons described in clauses (i) through (iv) of Section 8.2(e), either alone or collectively, own more than 35% of the beneficial interests.

(g) "Policy" shall mean this Conflict of Interests Policy of the Corporation as set forth in this Article VIII of the Corporation's Regulations, as the same may be amended or restated elsewhere, whether in this Code of Regulations, or any amendment and/or restatement of this Code of Regulations or any other governing instrument of the Corporation;

(h) "Transaction" shall mean any

(i) business dealings,

(ii) arrangement, agreement or undertaking with respect to the payment of Compensation by the Corporation,

(iii) agreement,

(iv) undertaking

(v) financial dealings,

(vi) relationship, or

(vii) other arrangement, circumstances or situation of any description or nature whatsoever,

involving the Corporation or to which the Corporation is a party.

Section 9.3. Conflict of Interests Policy. The Conflict of Interests Policy of the Corporation is as follows:

(a) Whenever an Interested Person believes that because of a Financial Interest of such Interested Person a Conflict of Interests exists, such Interested Person shall disclose in writing to the Board as soon as practical such Conflict of Interests and all material facts relating thereto. Such disclosure shall be made no later than such Interested Person's participation in any action or decision by the Corporation or meeting or vote of the Board or any committee of the Board pursuant to which the Corporation considers, approves or undertakes any Transaction involving such Conflict of Interests.

(b) With the Interested Person excused from such deliberations and any vote arising from such deliberations, the Board shall determine whether the Conflict of Interests requires that further steps be taken by the Board with respect to any deliberations or decisions concerning matters related to such Conflict of Interests or consideration or implementation of any Transaction relating to such Conflict of Interests.

(c) If it is determined that the Conflict of Interests disclosed by the Interested Person requires implementation of particular procedures or the taking of special actions by the Corporation, any or more of the following steps and/or actions like them may be taken:

(i) the Interested Person shall not participate in any meeting, discussion, deliberations or votes concerning the Conflict of Interests and the Transaction and/or Financial Interest giving rise to the Conflict of Interests;

(ii) if appropriate, a committee of non-interested Trustees or a non-interested Trustee may be appointed to investigate alternatives to any proposed Transaction involving a Conflict of Interest;

(iii) if it is determined after exercise of due diligence that the Transaction giving rise to a Conflict of Interests is or are:

(A) in the best interests of the Corporation,

(B) for the benefit of the Corporation,

(C) fair and reasonable to the Corporation, and

(D) that the Corporation cannot obtain a more advantageous Transaction with reasonable efforts under all facts and circumstances as then known to the Trustees,

(iv) the Transaction may be approved by a majority vote of non-interested Trustees eligible to vote on such matter.

(d) In order to protect the Corporation's best interests, appropriate disciplinary action shall be taken with respect to any Interested Person who violates this Conflict of Interests Policy; such disciplinary action need not necessarily be but may include expulsion from the Board, dismissal or similar action.

(e) The Corporation shall keep detailed records relating to any disclosure of a Financial Interest and/or a Conflict of Interest. Accordingly, the records of the Corporation, whether the minutes of the meetings of the Board, of committees with board delegated powers or otherwise should include:

(i) the names of persons who disclose a Conflict of Interests or a Financial Interest and what further actions, if any, were taken in light of such disclosure;

(ii) the names of the persons who were present for discussions and votes relating to any Transaction creating or giving rise to a Conflict of Interests, the content of such discussions, including particularly any alternatives to any proposed Transaction; and

(iii) a record of any votes taken with respect to the foregoing matters.

(f) The Corporation shall institute procedures to insure that this Conflict of Interests Policy is distributed to all Trustees and officers of the Corporation and to the members of any committee of the Corporation with board delegated powers. The Corporation shall require each such person to sign an annual statement that such person:

- (i) received a copy of the Conflict of Interests Policy;
- (ii) has read and understands the Conflict of Interests Policy;
- (iii) agrees to comply with the Conflict of Interests Policy;
- (iv) discloses on the annual statement any facts which may imply a Conflict of Interest;
- (v) understands that the Conflict of Interests Policy applies to all committees and subcommittees having board delegated powers; and
- (vi) understands that the Corporation is exempt from federal income taxes pursuant to Section 501(a) of the Code by virtue of being organized and operated as described in Section 501(c)(3) of the Code organization and that in order to maintain its tax-exempt status it must continuously engage primarily in activities which accomplish one or more of its tax-exempt purposes.

Section 9.4. Review of Corporate Activities. In furtherance of the Conflict of Interests Policy, the Board shall undertake a periodic review of the activities of the Corporation to insure that all activities of the Corporation are in furtherance of the tax-exempt purposes of the Corporation, are consistent with the accomplishment of such purposes and that such activities do not result in private inurement or impermissible private benefit to private interests. In reviewing the activities of the Corporation, the Board shall pay particular attention to:

- (a) whether Compensation arrangements and benefits provided to employees and/or independent contractors are reasonable and the result of the arm's-length negotiations;
- (b) whether any Transactions entered into by the Corporation result in private inurement or impermissible private benefits;
- (c) whether any partnership, joint venture or similar arrangements reflect reasonable payments for goods or services, further the exempt purposes of the Corporation and do not result in private inurement or private benefit; and
- (d) whether all other activities, agreements or undertakings of the Corporation are in furtherance of the Corporation's exempt purposes.

Article X The Executive Director

Section 10.1 Employment. The Board of Trustees shall be responsible for the hiring of the Executive Director, who shall be in charge of the day-to-day operations of The Bethany Center, subject only to the policy decisions of the Board of Trustees. The Executive Director shall be a non-voting member of the Board of Trustees and the Executive Committee and shall be a member, ex officio, of each and every committee designated in Article IV herein.

Section 10.2 Staff. The Executive Director shall select a staff, accountable to him/her, and shall be responsible for the training, definition of duties and conduct of each member of the staff. The Executive Director shall be responsible to see that The Bethany Center programs are adequately staffed at all times.

Section 10.3 Records The Executive Director shall supervise the keeping of the records and case histories of guests, keeping them safe from any and all improper use. The Executive Director shall also supervise and control purchasing and expenditures and appropriate the financial resources within the budget approved by the Board of Trustees.

Article XI Annual Audits

Section 11.1 There shall be an annual audit of the financial affairs of the Corporation by a CPA auditor approved by the Board of Trustees.

Article XII Miscellaneous

Section 12.1 All conveyances, contracts and instruments of transfer and assignment shall be specifically approved by the Board of Trustees and shall be executed on behalf of the Corporation by such officers or agents as may be specifically authorized by the Board of Trustees.

Section 12.2 All checks, drafts, bills of exchange, acceptances, notes or other obligations or orders for the payment of money shall be signed and counter-signed by such officers of the Corporation and/or other persons as the Board of Trustees shall from time to time by resolution designate.

Section 12.3 No loans and no renewals of any loans shall be contracted on behalf of the Corporation except as authorized by the Board of Trustees, or as otherwise provided by these By-Laws. When authorized so to do, any officer or agent of the Corporation may effect loans and advances for the Corporation from any bank, trust company or other institution or from any firm, corporation or individual, and for such loans and advances may make, execute and deliver promissory notes or other evidences of indebtedness of the Corporation. When authorized so to do, any officer or agent of the Corporation may pledge,

hypothecate or transfer, as security for the payment of any and all loans, advances, indebtedness and liabilities of the Corporation, any and all stocks, securities and other personal property at any time held by the Corporation, and to that end may endorse, assign and deliver the same. Such authority may be general or confined to specific instances.

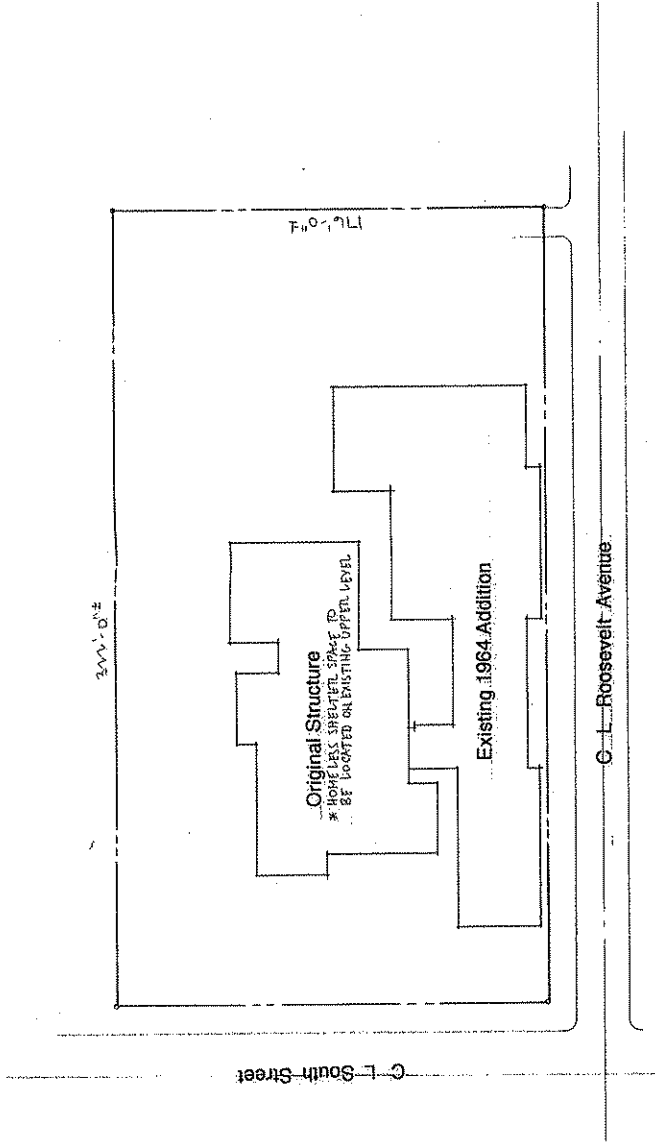

Existing Site Plan

SCALE: 1" = 30'-0"

CANDACE GOODALL
ARCHITECT

1200 Rogers Drive
P.O. Box 137
Piqua, Ohio 45356
cgoodall@att.net

Proposed Homeless Shelter Space	
The Bethany Center	
SCALE:	PROJECT:
DATE: JULY 1, 2009	PIQUA, OHIO 45356
339 SOUTH STREET	
DESIGNED BY:	CONTROL NUMBER
	PROJECT # 209114

ZONING MAP

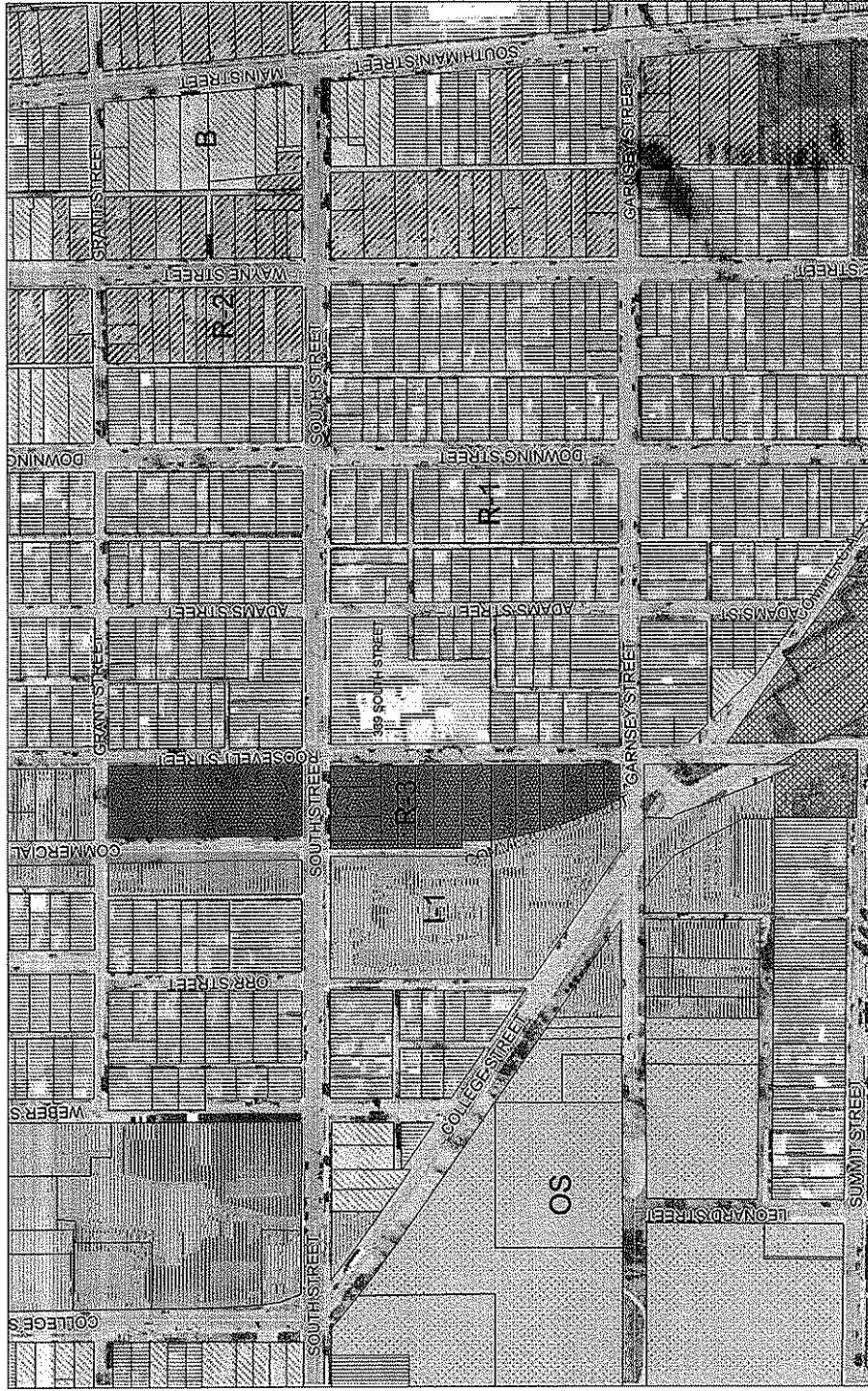

Zoning		R3-Multi-Family Residential
		R2-Two-Family Residential
		R1AA-One-Family Residential
		R1A-One-Family Residential
		R1-One-Family Residential
		OS-Open Space
		I2-Heavy Industrial
		I1-Light Industrial
		F-Floodplain
		CBD-Central Business District
		B - Business
Parcels		Parcels (auto-on)
Transportation		StreetNames
		Railroad
		Highway Symbols
		Interstate 75

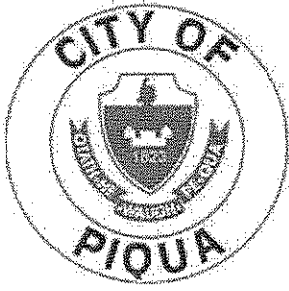

DEVELOPMENT OFFICE

Christopher W. Schmiesing – City Planner
201 West Water Street • Piqua, Ohio 45356
(937) 778-2049 • FAX (937) 778-5165
E-Mail: cschmiesing@piquaoh.org

February 26, 2010

***** MEETING NOTICE *****

Please be advised that the City of Piqua Planning Commission will conduct a meeting at the time and location stated below.

TIME: 6:00PM
DATE: Tuesday, March 9, 2010
LOCATION: Commission Chambers – 2nd Floor
Municipal Government Complex
201 W. Water Street

This letter serves to notify those persons who may have an interest in an agenda item to be discussed at this meeting. View the Planning Commission packet in its entirety online at http://www.piquaoh.org/agenda_plan_comm.htm or by visiting the Development Office.

This is your opportunity to speak in favor of, or object to, an item to be considered. If you desire to state your opinion concerning this matter and will be unable to attend the meeting, please submit your statement in writing to this office prior to 5pm on the date of the meeting.

Please contact this office if you have any questions pertaining to this notice.

Christopher W. Schmiesing
City Planner

Enc.

**PLANNING COMMISSION
MARCH 9, 2010
MAILING LIST**

RESOLUTION	NAME	MAILING ADDRESS	CITY STATE ZIP
MEETING NOTICE AND AGENDA TO:			
	MUNICIPAL GOVERNMENT COMPLEX PUBLIC BULLITEN BOARD		
PC 07-10	ED BLOCK	520 S MAIN STREET, SUITE 2531	AKRON OH 44311
PC 07-10	DOUG KNOUFF	1703 COMMERCE DRIVE	PIQUA OH 45356
PC 07-10	SUNSET COMMERCE HOLDINGS	122 N JEFFERSON ST	DAYTON OH 45402
PC 07-10	FOUREMAN DOUGLAS W & JACQUELINE R	1702 COMMERCE DRIVE	PIQUA OH 45356
PC 07-10	HUFFORD BOBBIE	147 N SUNSET DRIVE	PIQUA OH 45356
PC 07-10	POWERS FRED A & DANA	207 PETERS DRIVE	PIQUA OH 45356
PC 07-10	SPRUANCE JOHN T & LISA	205 PETERS DRIVE	PIQUA OH 45356
PC 07-10	LAVY JANE E	1708 COMMERCE DRIVE	PIQUA OH 45356
PC 07-10	PRINTZ JAMES A	4600 MIAMI-SHELBY RD	PIQUA OH 45356
PC 07-10	SHERRY MARC P	1808 CARLYLE DR	PIQUA OH 45356
PC 07-10	MED-TERRA INC	3130 N CO 25A RD	TROY OH 45373
PC 07-10	KENDALL DAVID W	110 JANET DRIVE	PIQUA OH 45356
PC 07-10	BROWN STEVEN R	122 N SUNSET DRIVE	PIQUA OH 45356
PC 07-10	GANGER WILLIAM M & BERTHA I	108 JANET DRIVE	PIQUA OH 45356
PC 07-10	A & A LTD	1711 COMMERCE DRIVE	PIQUA OH 45356
PC 07-10	CORNELIUS NANCY B (TOD)	P.O.BOX 730	PIQUA OH 45356
PC 07-10	LEBOEUF MARTIN G (LC) @(3)	P O BOX 1674	PIQUA OH 45356
PC 07-10	EUBA REAL ESTATE CORP	838 ELDEAN RD	TROY OH 45373
PC 07-10	PELLMAN WILMA L (LE) @(2)	106 JANET DR	PIQUA OH 45356
PC 07-10	DRAPP BARBARA J	104 JANET DR	PIQUA OH 45356
PC 07-10	KINSELLA ROBERT M	P.O.BOX 730	PIQUA OH 45356
PC 07-10	FRAZIER STEVEN D	102 JANET DRIVE	PIQUA OH 45356
PC 07-10	MILLER ROBERT J & BRANDON C	100 JANET DR	PIQUA OH 45356
PC 07-10	HARTZELL PROPELLER INC	1 PROPELLER PL	PIQUA OH 45356
PC 08-10	BROWN ROBERT	919 WASHINGTON AVENUE	PIQUA OH 45356
PC 08-10	JAMES RICK	502 TIMBERLEA TRAILS	KETTERING OH 45429
PC 08-10	HEMM DANIEL J	2596 W ST RT 47	SIDNEY OH 45365
PC 08-10	FINKES PROPERTIES LLC	1025 W GEISERMAN RD	PIQUA OH 45356
PC 08-10	ZIMMERMAN BURKHARDT J	2580 W FENNER RD	TROY OH 45373
PC 08-10	JAMES RENTSCHLER PROPERTY COMPANY LLC	P O BOX 602	PIQUA OH 45356
PC 08-10	SCARBROUGH FAMILY LIMITED PARTNERSHIP	3492 NE CAUSEWAY BLVD APT 401	JENSEN BEACH FL 34957
PC 08-10	SHERTEL COMPANY AN OHIO CORPORATION	P O BOX 742	PIQUA OH 45356
PC 09-10/10-10	THOBE SCOTT	621 SEDGWICK WAY	TROY OH 45373
PC 09-10/10-10	PRYFOGLE KEVIN R & KELLY S	320 N DOWNING ST	PIQUA OH 45356
PC 09-10/10-10	HANING CHAD & ANGELA M	324 N DOWNING ST	PIQUA OH 45356
PC 09-10/10-10	WESTMINSTER UNITED PRESBYTERIAN CH PIQ	325 W ASH ST	PIQUA OH 45356
PC 09-10/10-10	YMCA	223 W HIGH ST	PIQUA OH 45356
PC 09-10/10-10	SCOTT OKEY & THELMA	321 N DOWNING ST	PIQUA OH 45356
PC 09-10/10-10	CYRENE A M E CHURCH	227 W ASH ST	PIQUA OH 45356
PC 09-10/10-10	LUNA DONALD P	230 W HIGH ST	PIQUA OH 45356
PC 09-10/10-10	THOBE JOSEPH D & TRACY L EARLES THOBE	328 N DOWNING ST	PIQUA OH 45356
PC 11-10	BETHANY CENTER	339 SOUTH ST	PIQUA OH 45356
PC 11-10	MCGRAW III WILLIAM J	210 W MAIN ST	TROY OH 45373
PC 11-10	SOUTHVIEW NEIGHBOHOOD ASSOCIATION	714 S DOWNING ST	PIQUA OH 45356
PC 11-10	HAVENAR TAMMIE JO	1048 E STATLER RD	PIQUA OH 45356
PC 11-10	MIDDLETON GAIL L	705 LINCOLN ST	PIQUA OH 45356
PC 11-10	ANTHONY BETTY L	340 SOUTH ST	PIQUA OH 45356

**PLANNING COMMISSION
MARCH 9, 2010
MAILING LIST**

RESOLUTION	NAME	MAILING ADDRESS	CITY STATE ZIP
PC 11-10	ROOF VIVIAN M	336 SOUTH ST	PIQUA OH 45356
PC 11-10	YOUNG ANGELA K	342 SOUTH ST	PIQUA OH 45356
PC 11-10	PIQUA MANOR LTD	TWO MIRANOVA PLACE	COLUMBUS OH 43215
PC 11-10	BROWN LORA D	639 S ROOSEVELT AVE	PIQUA OH 45356
PC 11-10	LAWSON GENNIVEE E	635 S ROOSEVELT AVE	PIQUA OH 45356
PC 11-10	PUTNAM BRIAN M & FRANCES A	638 S ROOSEVELT AVE	PIQUA OH 45356
PC 11-10	HUBER LEWIS R & CLARA J	640 S ROOSEVELT AVE	PIQUA OH 45356
PC 11-10	SPANGENBERGER CAROL A	644 S ROOSEVELT AVE	PIQUA OH 45356
PC 11-10	CARNES INVESTMENTS III LLC	646 S ROOSEVELT AVE	PIQUA OH 45356
PC 11-10	RUSSELL JAMES A (TOD)	359 HOME AVE	PIQUA OH 45356
PC 11-10	HEMMERT WILLIAM J	1219 FOREST AVE	PIQUA OH 45356
PC 11-10	R & J PIQUA PROPERTIES LLC	520 FIRST ST	PIQUA OH 45356
PC 11-10	KINDELL DAWN (TOD)	622 S ROOSEVELT AVE	PIQUA OH 45356
PC 11-10	LEE WILSON JR & LAURA ARLENE	620 S ROOSEVELT AVE	PIQUA OH 45356
PC 11-10	LABREE DAVID	618 S ROOSEVELT AVE	PIQUA OH 45356
PC 11-10	3-H INVESTMENTS	PO BOX 729	PIQUA OH 45356
PC 11-10	SULLENBERGER RENTALS LLC	9829 N SPIKER	PIQUA OH 45356
PC 11-10	CLEM MARVIN TRUSTEE OF SHARON L HÜTER	622 ADAMS ST	PIQUA OH 45356
PC 11-10	HENNESSEY DAVID M & BARBARA E MILLER	624 ADAMS ST	PIQUA OH 45356
PC 11-10	OLDS THOMAS LEROY & CHARLYNE	626 ADAMS ST	PIQUA OH 45356
PC 11-10	VOORHIS WILMA I	628 ADAMS ST	PIQUA OH 45356
PC 11-10	ASHER JEREMIAH A	647 S ROOSEVELT AVE	PIQUA OH 45356
PC 11-10	RONCAL LEONOR M (TOD) @ (2)	643 S ROOSEVELT AVE	PIQUA OH 45356
PC 11-10	PENROD THOMAS E TRUSTEE OF THOMAS E PE	890 SNYDER RD	PIQUA OH 45356
PC 11-10	BROWN DARRELL K & JANET E	616 ADAMS ST	PIQUA OH 45356
PC 11-10	COLE JESSICA J	618 ADAMS ST	PIQUA OH 45356
PC 11-10	LAWRENCE KATHY JEAN	409 SOUTH ST	PIQUA OH 45356
ENTIRE PACKET TO:			
	FRED ENDERLE	INTER-OFFICE MAIL	
	CHRIS SCHMIESING	INTER-OFFICE MAIL	
	PLANNING COMMISSION	REGULAR MAIL	
E-MEETING NOTICE TO:			
	AMY WELKER	EMAIL	
	CHRIS BOEKE	EMAIL	
	CITY COMISSION	EMAIL	
	DEAN BURCH	EMAIL	
	DEBBIE STEIN	EMAIL	
	FRED ENDERLE	EMAIL	
	BILL MURPHY	EMAIL	
	LORNA SWISHER	EMAIL	
	MARTIN KIM	EMAIL	
	STACY WALL	EMAIL	
	AMY HAVENAR	EMAIL	
	BRUCE JAMISON	EMAIL	
	PIQUA DAILY CALL	EMAIL	
	DAYTON DAILY NEWS	EMAIL	
	WPTW	EMAIL	
	PIQUA CHANNEL 5	EMAIL	
	MIAMI COUNTY HOME BUILDERS ASSOCIAT	EMAIL	